

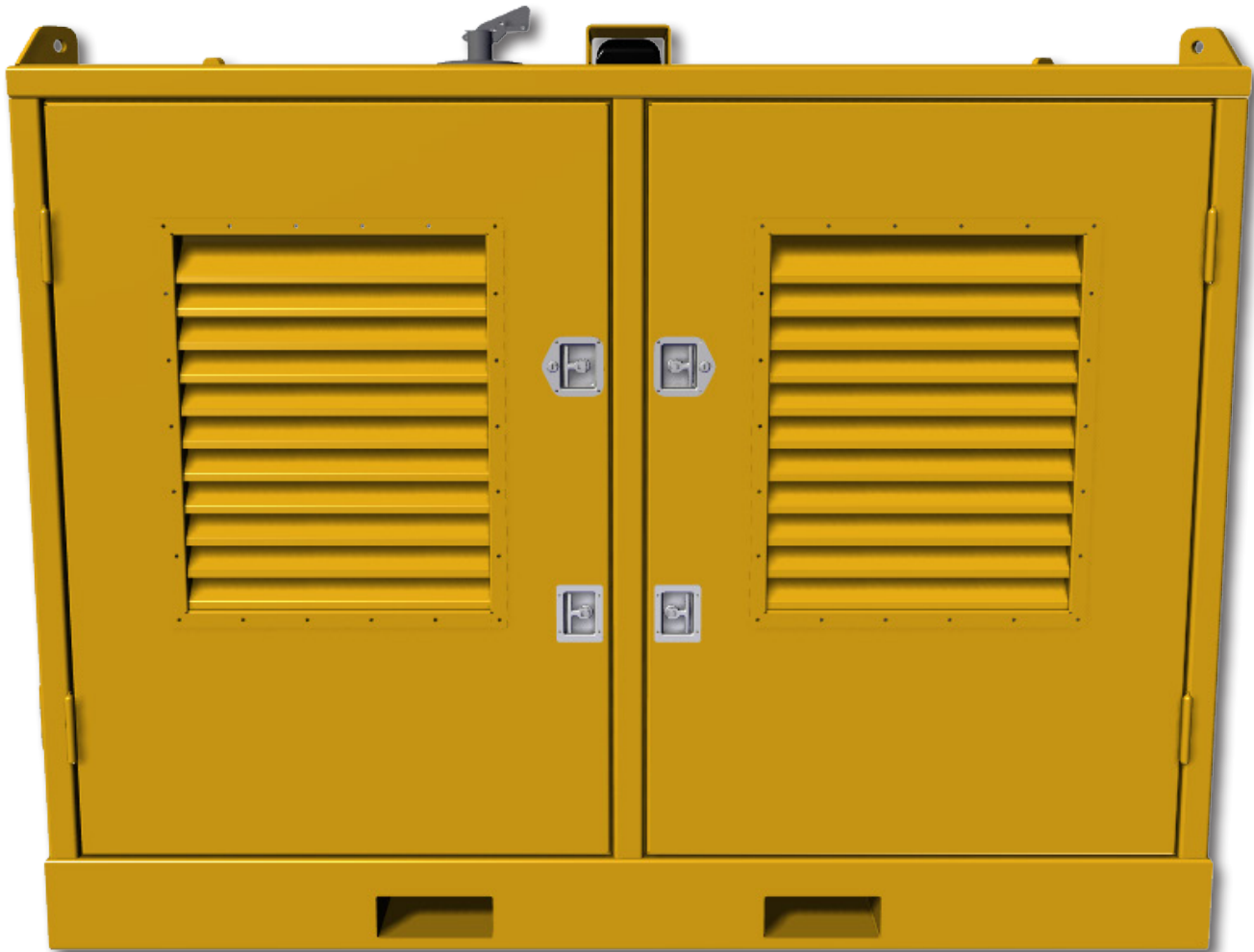

# APE POWER UNIT OWNER'S MANUAL

---

## DEEP FOUNDATION SOLUTIONS



**800-248-8498**

**WWW.AMERICANPILEDRIVING.COM**

**MODEL 127 POWER UNIT**

Copyright © 2020 American Piledriving Equipment Inc. All Rights Reserved

**Copyright © 2020 American Piledriving Equipment Inc.**

*All rights reserved, No part of this publication may be reproduced, distributed, or transmitted in any form of by any means, including photocopying, recording, or other electronic or mechanical methods, without prior written permission of the publisher. For permission requests, write to the publisher, addressed “**Attention: American Piledriving Equipment Manual Division**” at the address below.*

AMERICAN PILEDRIVING EQUIPMENT, INC.

7032 S. 196th Street

Kent, Washington 98032

Office: 253-872-0141

Toll Free: 800-248-8498

Fax: 253-872-8710

APE\_Manuals@americanpiledriving.com



**800-248-8498**

**WWW.AMERICANPILEDRIVING.COM**

**MODEL 127 POWER UNIT**

Copyright © 2020 American Piledriving Equipment Inc. All Rights Reserved

---

# Quick Reference Guide

---

This Quick Reference Guide will assist you in finding the information you're looking for.

**GENERAL INFORMATION**

**MAINTENANCE**

**TROUBLE SHOOTING**

**REPLACEMENT PARTS**

**REFERENCE / NOTES**

A Table of Contents is included after the Foreword.

**Description:**

**MODEL 127 POWER UNIT**



# WARRANTY INFORMATION

American Piledriving Equipment, Inc. (APE) warrants new products sold by it to be free from defects in material or workmanship for a period of two (2) years after the date of delivery to the first user and subject to the following conditions:

- APE's obligation and liability under this WARRANTY is expressly limited to repairing or replacing, at APE's option, any parts which appear to APE upon inspection to have been defective in material or workmanship. Such parts shall be provided at no cost to the user, at the business establishment of APE or the authorized APE distributor of the product during regular working hours.
- This WARRANTY shall not apply to component parts or accessories of products not manufactured by APE, and which carry the warranty of the manufacturer thereof, or to normal maintenance (such as engine tune-up) or normal maintenance parts (such as filters).
- Replacement or repair parts installed in the product covered by this WARRANTY are warranted only for the remainder of the warranty as if such parts were original components of said product.
- APE makes no other warranty, expressed or implied, and makes no warranty of merchantability or fitness for any particular purpose.
- APE's obligations under this WARRANTY shall not include any transportation charges, costs of installation, duty, taxes or any other charges whatsoever, or any liability for direct, indirect, incidental or consequential damage or delay.
- If requested by APE, products or parts for which a warranty claim is made are to be returned, transportation prepaid, to APE.

OIL MUST MEET ISO CLEANLINESS CODE 17/15/11.  
OIL THAT DOES NOT MEET CLEANLINESS CODE  
WILL **VOID** THE WARRANTY

ANY IMPROPER USE, INCLUDING OPERATION  
AFTER DISCOVERY OF DEFECTIVE OR WORN  
PARTS, OPERATION BEYOND RATED CAPACITY,  
SUBSTITUTION OF ANY PARTS WHATSOEVER,  
USE OF PARTS NOT APPROVED BY APE OR ANY  
ALTERATION OR REPAIR BY OTHERS IN SUCH A  
MANNER AS, IN APE'S JUDGMENT, AFFECTS THE  
PRODUCT MATERIALLY AND ADVERSELY, SHALL  
**VOID** THIS WARRANTY.

ANY TYPE OF WELDING ON APE'S EQUIPMENT  
WILL **VOID** THE WARRANTY UNLESS AUTHORIZED  
IN WRITING BY APE

NO EMPLOYEE IS AUTHORIZED TO CHANGE  
THIS WARRANTY IN ANY WAY OR GRANT ANY  
OTHER WARRANTY UNLESS SUCH CHANGE IS  
MADE IN WRITING AND SIGNED BY AN OFFICER  
OF APE, INC.

---

# FOREWORD

---

This manual covers **APE Hydraulic Power Unit** safety, operation instructions, lubrication and maintenance information. This manual should be stored in or near the engine area in a literature holder or literature storage area.

The data provided in this manual gives the necessary information to operate and maintain APE equipment. The listed procedures are to be performed by qualified personnel who have an understanding of the equipment and who follow all safety precautions.

Some photographs or illustrations in this manual show details or attachments that may be different from your equipment. Continuing improvement and advancement of product design may have caused changes to your equipment which are not included in this manual. Whenever a question arises regarding your equipment, or this manual, please consult with your APE dealer for the latest available information.

## Using this manual:

- Refer to the Table of Contents for the page location of applicable sections.
- All weights and measurements are in English and Metric units.
- Please visit [www.americanpiledriving.com](http://www.americanpiledriving.com) for product data sheets and manuals and latest available information.

## **DISCLAIMER:**

This unit was tested and flushed before leaving our facility. In order to help provide years of trouble-free usage, please review the following documentation and make sure to clean and flush the quick disconnect fitting on any equipment before connecting it to the power unit.

Refer to schematic diagrams and the BOM (Bill of Materials) for component part specifications and recommended spare parts.

When calling APE, always have the equipment serial number on hand in order to obtain quicker service.



---

# TABLE OF CONTENTS

---

TABLE OF CONTENTS.....	6
SPECIFICATIONS.....	7
GENERAL SAFETY PRECAUTIONS .....	8
SAFETY MESSAGES .....	10
GENERAL HAZARD INFORMATION .....	11
BURN PREVENTION .....	12
BEFORE STARTING ENGINE.....	13
ENGINE STARTING .....	13
ENGINE STOPPING.....	14
ELECTRICAL SYSTEM.....	14
LIFTING AND STORAGE .....	15
MANUAL VALVE CONTROL .....	15
EQUIPMENT OVERVIEW.....	16
PRODUCT INFORMATION SECTION.....	17
CONNECTING THE HYDRAULICS.....	18
CONTROL PANEL OVERVIEW .....	19
SYSTEM START UP:.....	21
CONTROL GAUGES SCREEN .....	21
CONTROL PANEL OPERATIONS.....	22
CONTROL TRANSMITTER INFORMATION .....	23
TROUBLESHOOTING .....	28
HYDRAULIC SCHEMATIC.....	29
ELECTRICAL SCHEMATIC .....	31
HANDHELD TROUBLESHOOTING .....	33
SETTING UP THE PROGRAM .....	34
PROGRAMMING .....	34
REPLACEMENT PARTS .....	35
MANIFOLD.....	36
COOLER ARRANGEMENT .....	37
PUMP ARRANGEMENT.....	37
REFERENCE / NOTES.....	38



# SPECIFICATIONS

## DIMENSIONS

Overall Length	96 in	(244 cm)
Overall Width	61 in	(153 cm)
Overall Height	80 in	(202 cm)
Weight	7,500 lbs	(3,402 kg)
Fuel Capacity	60 gal	(227.1 L)

## ENGINE

Type	Caterpillar C4.4	
Horse Power	127 hp	(95 kW)
Displacement	269 in <sup>3</sup>	( cc)
Compression Ratio	16.2:1	
Engine Speed	1800 rpm	
Engine Oil	Caterpillar Diesel Engine Oil 10W30 or 15W40 Minimum 5.3 qt (US)(5 Liters) Maximum 7.3 qt (US)(7 Liters)	



## HYDRAULICS

Drive Pressure	0 - 2,500 psi	(172 bar)
Drive Flow	Variable	(***LPM)
Clamp Pressure	0 - 4,800 psi	(330 bar)
Clamp Flow	10 gpm	(38 LPM)
Hydraulic Oil	Envirollogic 146	
Hydraulic Capacity	160 gal	( 605L)

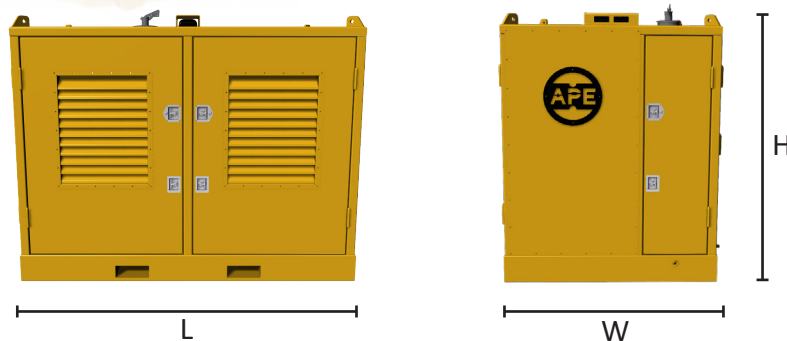



# Safety Section

## General Safety Precautions



DANGER indicates a hazardous situation which, if not avoided, will result in death or serious injury.



WARNING indicates a hazardous situation which, if not avoided, could result in death or serious injury.



CAUTION indicates a hazardous situation where injury could occur but is unlikely to be serious or lead to death.



NOTICE indicates information that may help or guide you in the operation or service of the equipment.

### DISCLAIMER:

This unit was tested and flushed before leaving our facility. In order to help provide years of trouble free usage, please review the following documentation and make sure to clean and flush the field piping before connecting it to the power unit.

Refer to schematic diagrams and the BOM (Bill of Materials) for component part specifications and recommended spare parts.

When calling APE (American Piledriving Equipment), always inform them of the supplied serial # in order to obtain quicker service

## NOTICE

### **READ THIS MANUAL THOROUGHLY BEFORE OPERATING AND / OR WORKING ON THE EQUIPMENT**

1. Read and follow any safety instructions in the CATERPILLAR ENGINE OPERATOR'S MANUAL.
2. Only well-trained and experienced personnel should attempt to operate or maintain this equipment.
3. NEVER adjust, lubricate and/or repair the unit when it is in operation or lifted above ground level.
4. NEVER remove, paint over and/or cover warning or safety labels. If labels become damaged or unreadable, replace immediately.
5. All personnel should wear approved safety clothing including HARD HATS, SAFETY SHOES, SAFETY GLASSES and HEARING PROTECTION when near this equipment.
6. Do **NOT** stand any closer to this equipment than necessary when it is in operation. Parts may loosen and fall. **NEVER** stand under operating or elevated equipment.
7. When maintaining and/or repairing the equipment, **NEVER** substitute parts not supplied or approved in writing by APE.

## NOTICE

### **Do NOT weld or flame cut on this equipment.**

8. NEVER use or store flammable liquids on or near the engine.
9. Insure that all lifting equipment, including cranes, wire rope, slings, hooks, shackles, etc., are properly sized for the worst caseloads anticipated during operations.
10. If there are any questions about the weights, specifications and/or performance of the unit, contact APE before handling and/or operating the equipment.
11. Check wire rope clips for tightness and wire ropes for wear daily.
12. Insure that ground vibrations will not damage or collapse adjacent structures or excavations.



## Safety Section



***When operating in an enclosed area, exhaust fumes should be piped outside. Continued breathing of exhaust fumes may prove FATAL.***

13. Remove all tools, parts and/or electrical cords before starting the unit.
14. When servicing batteries, do **NOT** smoke and/or use an open flame in the vicinity. Batteries generate explosive gas during charging. There must be proper ventilation when charging batteries.
15. When filling the fuel tank, do **NOT** smoke and/or use an open flame in the vicinity.
16. If abnormal equipment operation is observed, discontinue use immediately and correct the problem.
17. Do **NOT** leave the equipment control pendant (radio control) unattended.
18. Store oily rags in approved containers and away from the engine exhaust system.
19. If running an auger/drill, make sure that the Auger rotation switch is in NEUTRAL before starting the Power Unit engine
20. Do **NOT** adjust and/or set the hydraulic pressures higher and/or lower than those specified in this Manual.
21. NEVER operate this equipment with hydraulic hoses that are damaged or 'kinked'. Replace damaged hoses immediately.
22. Do **NOT** lift and/or support hydraulic hoses with wire rope slings.
23. NEVER attempt to connect Quick Disconnects (QDs) when the Power Unit is running.
24. Do **NOT** pull on and/or attempt to move equipment with the hydraulic hoses.
25. Do **NOT** attempt to locate hydraulic leaks with your hands. High-pressure leaks can penetrate skin and cause severe damage, blood poisoning and/or infection.
26. Do **NOT** attempt to repair leaks while the equipment is in operation.
27. Do **NOT** attempt to tighten and/or loosen fittings and/or hoses when the machine is in operation.
28. Power Unit must always be placed on level, stable ground.
29. Do **NOT** remove Power Unit heat shields. Do NOT

attempt to use the Power Unit without heat shields. Severe fires may result.

## NOTICE

***A properly maintained fire extinguisher, suitable for oil fires, MUST be kept in the immediate vicinity of equipment operations.***

30. When moving and/or transporting this equipment, insure that the vehicle and/or vessel is of sufficient capacity to handle the load. Make sure that the equipment is properly tied down.
31. When moving and/or transporting this equipment, be sure that the QD Dust Caps are tight and that the cap safety cables are in place. Be sure that all equipment parts are tight and/or properly secured before shipment. Unsecured parts may vibrate loose and fall during transport causing injury and/or property damage.
32. Rounded and/or damaged bolt heads and/or nuts should be replaced so that proper torque values may be obtained. Proper torque values are necessary to prevent parts on this equipment, leads and/or crane booms from loosening and/or falling. (Refer to the torque chart in this manual for the proper values.)
33. When operating in a closed area, pipe exhaust fumes outside. (**Warning:** Breathing exhaust fumes can cause serious injury or even death.)
34. When loading or unloading the power unit using a forklift, the forks must be placed under the entire depth of the unit.
35. Keep hands away from rotating flighting auger shaft and/or rotary joint.
36. Do **NOT** allow clothing, hoses, ropes, etc., to be entangled in, or wrap around, rotating flighting, Auger Shaft and /or rotary joint.
37. Never stand under an equipment at any time and keep your eyes on the equipment when it is in operation.



### Safety Messages

There may be several specific safety messages on your equipment. The exact location and description of the safety messages are reviewed in this section. Become familiar with all safety messages.

Ensure that all the safety messages are legible. Clean the safety messages or replace the safety messages if the words cannot be read or if the illustrations are not visible. Use a cloth, water and soap to clean the safety messages. Do not use solvents, gasoline, or other harsh chemicals. Solvents, gasoline, or harsh chemicals could loosen the adhesive that secures the safety messages. The safety messages that are loosened could drop off the equipment.

Replace any safety message that is damaged or missing. If a safety message is attached to a part of the equipment that is replaced, install a new safety message on the replacement part. Your APE dealer can provide new safety messages.



Do not operate or work on this equipment unless you have read and understand the instructions and warnings in the Operation and Maintenance Manual. Failure to follow the instructions or read the warnings could result in injury or death. Contact any APE dealer for replacement manuals. Proper care is your responsibility.

### Quick Disconnect Notice

**NOTICE:** QUICK DIS-CONNECTS MUST BE FULLY SEATED TO ALLOW FREE HYDRAULIC FLOW. BLOCKED HYDRAULIC FLOW WILL STOP OR SLOW OPERATIONS AND CAUSE EXCESSIVE HEAT. TO SOLVE PROBLEM, REMOVE CLEAN AND RE INSTALL FITTINGS

Make sure all QD's are installed and connected completely. Failing to do so may cause damage or prevent proper operation.

### Identification Tag



This information is important when contacting APE for replacement parts or other information.

- \* Model
- \* Serial No.

### Transport



Ship with the hydraulic tank forward to prevent damage to the radiator cooling package at the front of the power unit skid.

### Do Not Weld



Do **NOT** weld on or around the power unit unless authorized in writing by APE. Doing so will void all warranties and may cause damage to the power unit or vibro.

### Oil Filters



Only CAT filters are to be used when replacing engine filters. Any other filter will void engine warranty and cost damages. Fees will apply.

### General Hazard Information



Attach a “Do Not Operate” warning tag to the start switch or controls before the equipment is serviced or repaired. Attach the warning tags to the engine and to each operator control panel. When appropriate disconnect the negative terminal on the battery.

Do not allow unauthorized personnel on the equipment or around the equipment while being serviced.

Cautiously remove the following parts. To help prevent spraying or splashing of pressurized fluids hold a rag over the part that is being removed.

- Filler caps
- Grease fittings
- Pressure taps
- Breathers
- Drain plugs

### Pressurized Air and Water

Pressurized air and/or water can cause debris and/or hot water to be blown out which could result in personal injury.

The maximum air pressure for cleaning purposes must be reduced to 30psi (205 kPa) when the air nozzle is deadheaded and used with effective chip guarding (if applicable) and personal protective equipment. The maximum water pressure for cleaning purposes must be below 40psi (275 kPa). When pressurized air and/or pressurized water is used for cleaning, wear protective clothing, protective shoes, and eye protection. Eye protection includes goggles or a protective face shield. Always wear eye protection for cleaning the cooling system.

Avoid direct spraying of water on electrical connectors, connections, and components. When using air for cleaning, allow the equipment to cool to reduce the possibility of fine debris igniting when redeposited on hot surfaces.

### Fluid Penetration

Always use a board or cardboard when you check for a leak. Leaking fluid that is under pressure can penetrate body tissue. Fluid penetration can cause serious injury and possible death. A pin hole leak can cause severe injury. If fluid is injected into your skin, you must get medical treatment immediately. Seek treatment from a doctor that is familiar with this type of injury.

### Containing Fluid Spillage

**NOTICE**

Care must be taken to ensure that fluids are contained during performance of inspection, maintenance, testing, adjusting, and repair of the equipment. Be prepared to collect the fluid

GENERAL INFORMATION



with suitable containers before opening any compartment or disassembling any component containing fluids.

Dispose of all fluids according to local regulations and mandates.

### Lines, Tubes, and Hoses

Do not bend or strike high-pressure lines. Do not install lines, tubes, or hoses that are damaged.

Repair any fuel lines, oil lines, tubes, or hoses that are loose or damaged. Leaks can cause fires or injury.

Inspect all lines, tubes, and hoses carefully. Do not use bare hands to check for leaks. Always use a board or cardboard for checking equipment components for leaks. Tighten all connections to the recommended torque.

Check for the following conditions:

- End fittings that are damaged or leaking
- Outer covering that is chafed or cut
- Wire that is exposed in reinforced hose
- Outer covering that is ballooning locally
- Flexible part of the hose that is kinked or crushed
- Armoring that is embedded in the outer covering

Ensure that all of the clamps, guards, and heat shields are installed correctly. Correct installation of these components will help to prevent these effects: vibration, rubbing against other parts and excessive heat during operation.

### Inhalation

Exhaust fumes can be hazardous to your health. If you operate the equipment in an enclosed area, adequate ventilation is necessary,

### Burn Prevention

Do not touch any part of the equipment during operation. Allow the equipment to cool before any maintenance is performed on the engine. Relieve all pressures in the hydraulic system, fuel system, lubrication system, or cooling system before any lines, fittings, or related items are disconnected.

### Coolant

When the engine is at operating temperature, the engine coolant is hot. The coolant is also under pressure. The radiator and all lines to the heaters or to the engine contain hot coolant. When pressure is relieved rapidly, the hot coolant can turn into steam.

Any contact with hot coolant or with steam can cause severe burns. Allow cooling system components to cool before the cooling system is drained.

Check the coolant level only after the engine has been stopped.

Do not step on the engine in order to remove the filler cap. Ensure that the filler cap is cool before removing the filler cap. Remove the filler cap slowly in order to relieve pressure.

Cooling system conditioner contains alkali. Alkali can cause personal injury. Do not allow alkali to contact the skin, the eyes, or the mouth.

### Oil

Hot oil and hot components can cause personal injury. Do not allow hot oil or hot components to contact the skin.

Keep all of the exhaust manifold and turbocharger heat shields in place in order to protect components from oil spray if there is a failure of a line, tube, or seal.

### Batteries

The battery electrolyte is acidic. Battery acid can cause personal injury. Do not allow battery acid to come in contact with the skin or the eyes. Always wear protective glasses for servicing batteries. Wash hands after touching the batteries and connectors. The use of gloves is recommended.

Batteries give off combustible gases which can explode. Ensure proper ventilation for batteries that are in an enclosure. Never disconnect any charging unit circuit or battery circuit cable from the battery when the charging unit is operating. A spark can cause the combustible gases to ignite. Do not smoke when batteries are serviced.

Always thaw a frozen battery before jump starting the battery. Frozen batteries can explode.

### Crushing Prevention and Cutting Prevention

Support the equipment properly when work beneath the equipment is performed.

Unless other maintenance instructions are provided never attempt adjustments while the engine is running.

Stay clear of all rotating parts and moving parts. Leave the guards in place until maintenance is performed. After the maintenance is performed reinstall the guards.

Keep objects away from moving fan blades. The fan blades will throw objects or cut objects.

Wear protective glasses in order to avoid injury to the eyes.

Chips or other debris may fly off objects when objects are struck. Before objects are struck, ensure that no one will be injured by flying debris.

### Mounting and Dismounting

Do not climb on the equipment, and do not jump off the equipment. Do not stand on the components which can not support your weight. Mount the equipment and dismount the equipment only at locations that have a ladder or handholds.

### Before Starting Engine

Inspect the engine for potential hazards.

All protective guards and all protective covers must be installed if the engine must be started in order to perform service procedures. To help prevent an accident that is caused by parts in rotation, work around the parts carefully.

Do not bypass the automatic shutoff circuits. Do not disable the automatic shutoff circuits. The circuits are provided in order to help prevent personal injury and equipment damage.

On the initial start-up of a new engine or an engine that has been overhauled, be prepared to stop the engine if a problem occurs.

### Engine Starting

If a warning tag or do not operate tag is attached to the engine start switch or to the controls, DO NOT start the engine or move the controls. Consult with the person that attached the warning tag before the engine is started.

All protective guards and all protective covers must be installed if the engine must be started in order to perform service procedures. To help prevent an accident that is caused by parts in rotation, work around the parts carefully.

Start the engine from the operator's panel or remote pendant start switch.



Always start the engine according to the procedure that is described in this Operation and Maintenance Manual, “Engine Starting” topic (Operation Section). Knowing the correct procedure will help to prevent major damage to the engine components. Knowing the procedure will also help to prevent personal injury.

Engine exhaust contains products of combustion that can be harmful to your health. Always start and operate the engine in a well ventilated area. If the engine is run in an enclosed area, vent the engine exhaust outside.

### Engine Stopping

Stop the engine according to the procedure in the Operation and Maintenance Manual, “Engine Stopping (Operation Section)” in order to avoid overheating of the engine and accelerated wear of the engine components.

Use the Emergency Stop Button ONLY in an emergency situation. **Do not use the Emergency Stop Button for normal engine stopping.** After an emergency stop, DO NOT start the engine until the problem that caused the emergency stop has been corrected.

Stop the engine if an overspeed condition occurs during the initial start-up of a new engine or an engine that has been overhauled. This may be accomplished by shutting off the fuel supply to the engine and/or shutting off the air supply to the engine.

To stop an electronically controlled engine, cut the power to the engine.

### Electrical System

Never disconnect any charging unit circuit or battery circuit cable from a battery when the charging unit is operating. A spark can cause the combustible gases that are produced by some batteries to ignite.

If the engine must be started by an external electrical source, then always connect the positive jump start cable “+” to the positive terminal “+” of the battery.

To help prevent sparks from igniting combustible gases that are produced by some batteries, the negative “-” jump start cable should be connected last from the external power source to the negative “-” terminal of the starting motor. If the starting motor is not equipped with a negative “-” terminal, connect the jump start cable to the engine block.

### Grounding Practices

Proper grounding for the equipment electrical system is necessary for proper engine performance and reliability. Improper grounding will result in uncontrolled electrical circuit paths and unreliable electrical circuit paths.

Uncontrolled equipment electrical circuit paths can result in damage to the engine and pumps. All grounds should be tight and free of corrosion. The alternator and the starting motor must be grounded to the negative “-” battery terminal.

A grounding strap must be used for all equipment that has an alternator grounded to an engine component. The ground strap must be connected to the component and to the negative “-” battery

# Operation Section

terminal. The component must be electrically isolated from the engine.

A ground plate with direct path to the negative battery terminal “-” can be used as a common ground point for the components of one engine system.

When servicing a power unit, make sure to disconnect both battery cables starting with the ground wire from the negative terminal on the battery. Not disconnecting the battery can cause damages to the ECM, fees will apply, warranties will be voided.

## Lifting and Storage

Always load the power unit with the hydraulic tank facing the front of the truck, to prevent damage to the cooler and radiator from flying debris. When lifting the power unit, position the forklift forks forward as far as possible to prevent load shifts. See Photo.

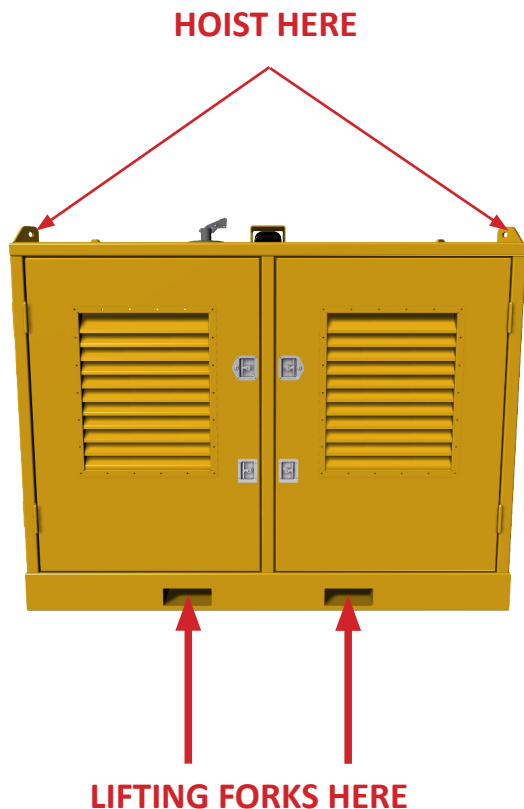

## Manual Valve Control

You can manually control the drive and clamp functions by pushing these hands forward or pulling these handles backwards.

### Drive Function

Push to Engage drive forward  
Pull to Engage drive reverse

### Clamp Function

Push to open clamp  
Pull to close clamp

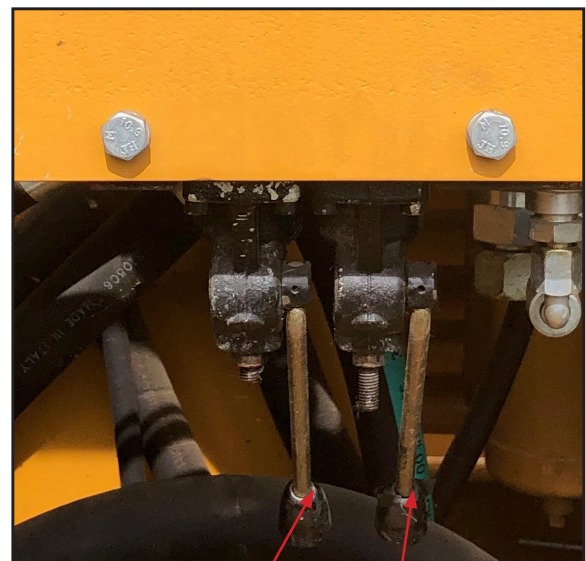

CLAMP  
CONTROL

DRIVE  
CONTROL



# Product Information Section

## Equipment Overview

GENERAL INFORMATION

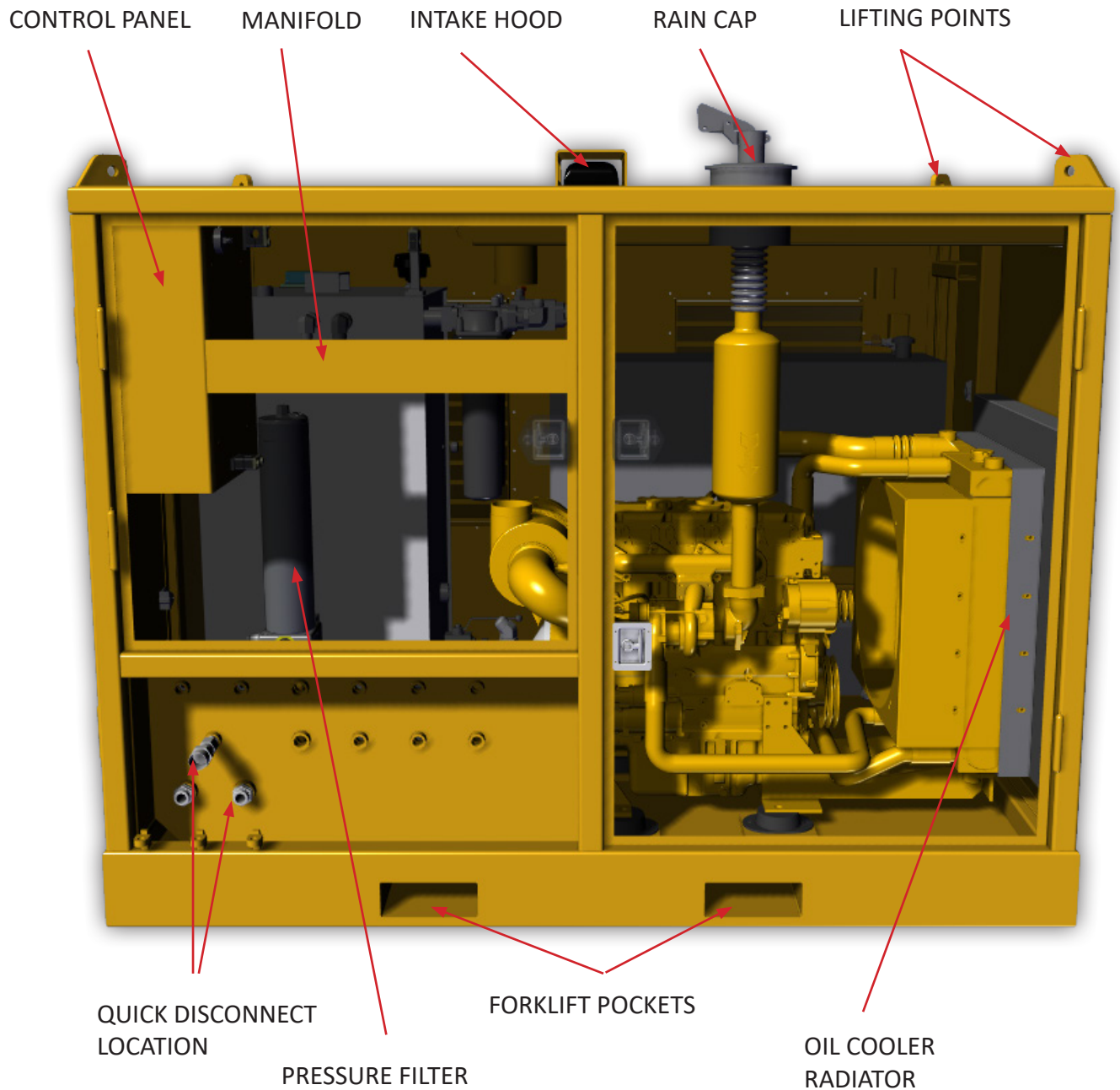

# Product Information Section

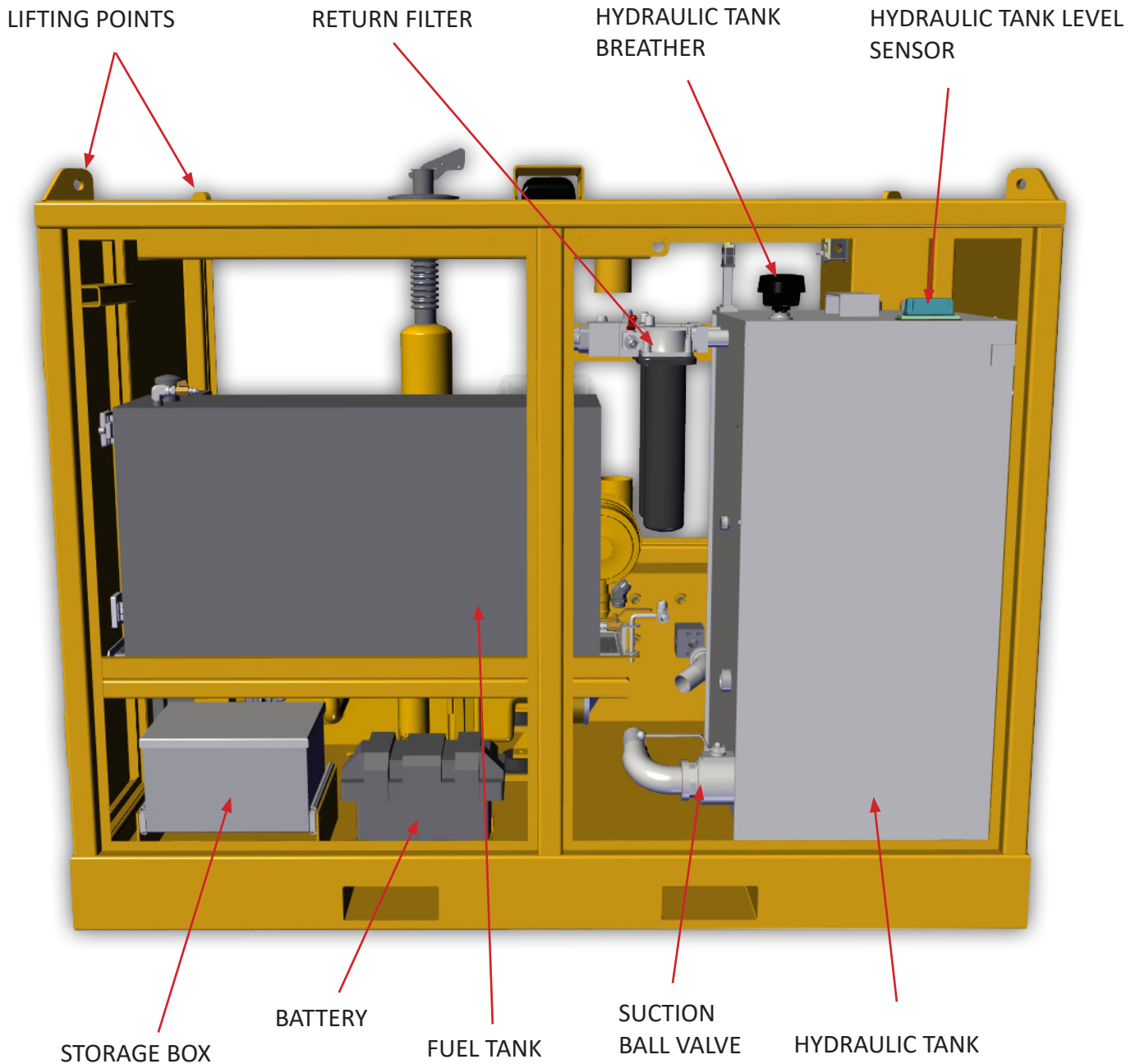

# Operation Section

## Connecting the Hydraulics

Connecting the hoses is one of the most critical aspects of commissioning an APE tool.

Take extreme care to keep these connections absolutely clean. This procedure is one of the most common ways for foreign particles to be introduced into a hydraulic system.

To connect the tool to the power unit:

1. Turn the power unit OFF.
2. Position power unit close enough to work that hoses will be able to reach.
  - Most hose failures are caused by pulling hoses off couplers. Avoid pulling on hoses.
3. Clean all quick disconnects with brake wash. They must be completely free of dirt or contaminants.
4. Attach quick disconnects. Note that quick disconnects of each hose type are mated to prevent backwards hookups.
5. Tighten all fittings to hand tightness. Verify with chain wrench.
  - DO NOT OVER TIGHTEN

***New hydraulic fluid is NOT clean oil!***

***Oil must meet ISO cleanliness code 17/15/11***

Please do the following:

- Set the engine at idle
- Run at idle for about 10 minutes to fill the lines
- Drive will not engage until the power unit is up to operating temperature.

# Attention!

**Pressurizing the system while there is air entrained in the fluid may cause damage to the components.**

**Let the system run at idle for an additional 10 minutes to allow the air to rise into the airspace of the hydraulic reservoir.**

CLAMP OPEN      CLAMP CLOSE  
CASE DRAIN      AUX LINE

DRIVE  
REVERSE

DRIVE  
FORWARD



# CONTROL PANEL OVERVIEW

## Control Panel Overview

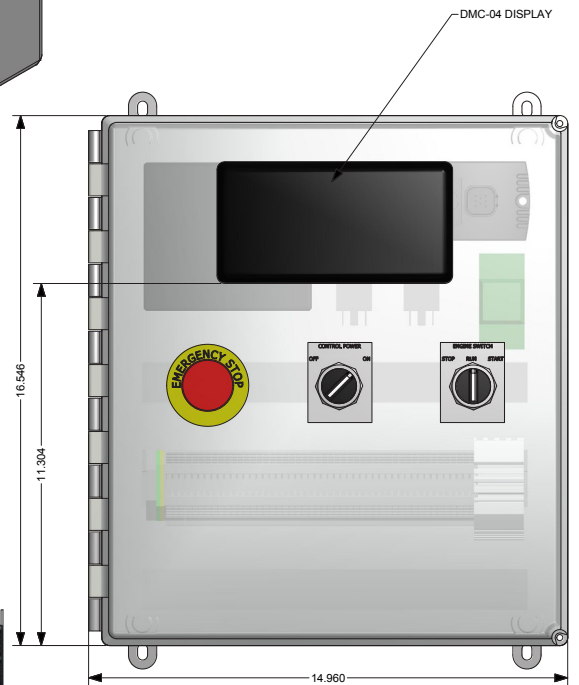
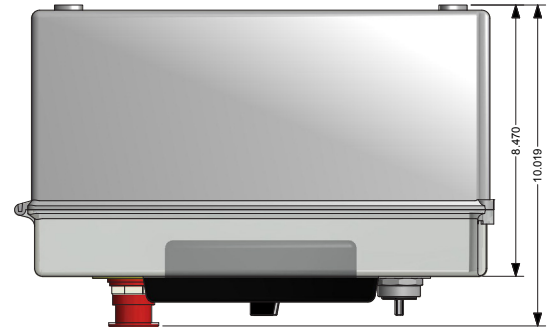
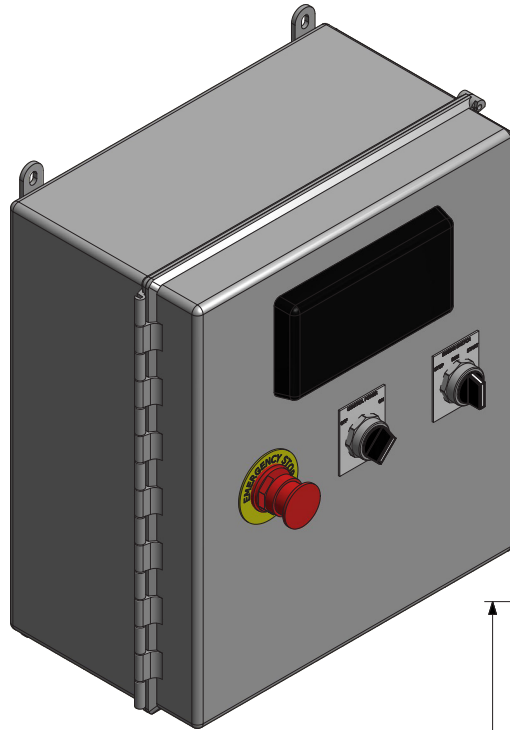

40-PIN AND 24 PIN DEUTSCH PLUG TO MOUNT ON BOTTOM OF ENCLOSURE AS INDICATED

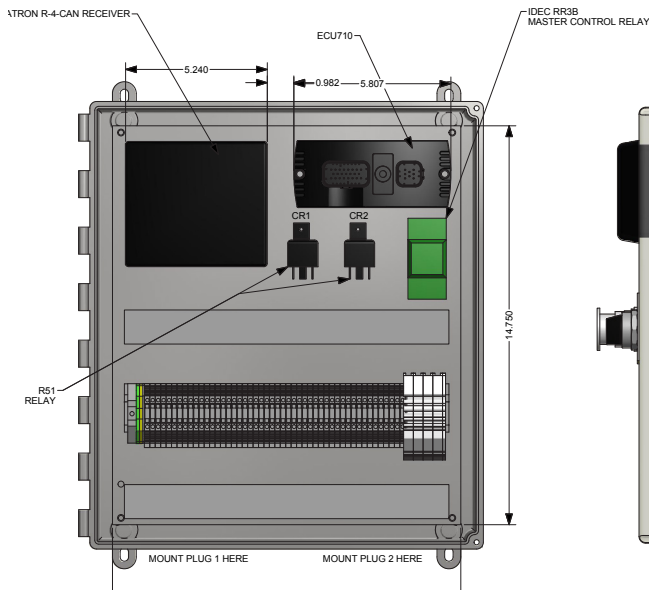

GENERAL INFORMATION

R



# CONTROL PANEL OVERVIEW

## ATTENTION:

WILL SHUT OFF ENGINE, DISENGAGE DRIVE AND ALL VALVES INSTANTLY.

Control panel will stay on.

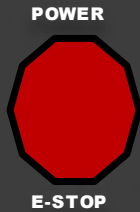

## DISPLAY

This is where you will be able to view Engine oil pressure, Engine Rpm, Hydraulic Pump Pressure, Engine Coolant Temperature, and Engine load, IF an issue comes up, you will be able to see it in the diagnostic screen as well be able to see the control button screen.

## EMERGENCY ENGINE STOP

### EMERGENCY USE ONLY

Do not use unless it's an emergency.

This will shut off the engine, disengage drive and all valves instantly. The control panel power will stay on.

Clamp will stay closed but will not stay energized unless the emergency stop is disengaged.

## CONTROL PANEL POWER ON / OFF

This will turn the power on to the control panel. The power must be on to run the unit.

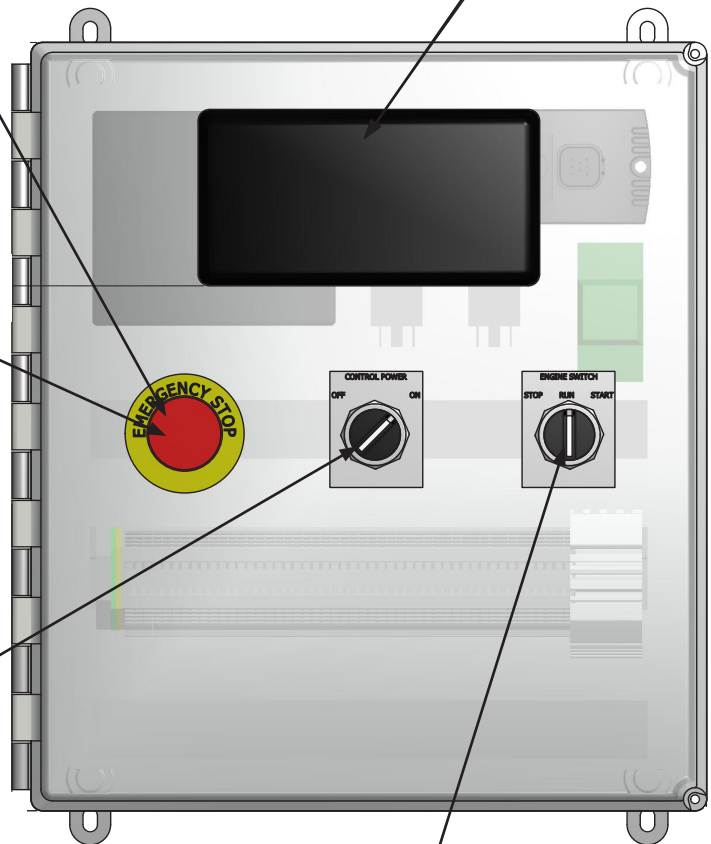

## ENGINE SWITCH STOP / RUN / START

This will stop or start the engine on to the control panel. Once you start the engine, the switch will stay on run to keep the engine on. To stop the engine, turn the switch to stop. The Control power must be on to run the unit.



# START UP OPERATIONS

## System Start Up:

- Verify Engine Switch is in Stop position and E-stop on Handheld and Box are pulled out.
- Verify Handheld is switched on.
- Turn Control Power switch to 'ON' position.
- Wait for screen to finish boot up.
- Turn Engine Switch to start position until engine starts and then release (operates like standard key switch).

## Operating Temperatures

The Operating Temperature references the internal temperature of the engine.

Take into consideration the following requirements:

- 70°C (158°F) – Avoid going over this Operating Temperature for improved service life
- 75°C (168°F) – Highest permissible intermittent Operating Temperature
- -35°C (-31°F) – Lowest permissible Operating Temperature

## Control Gauges Screen

Display boots up to this gauge screen.

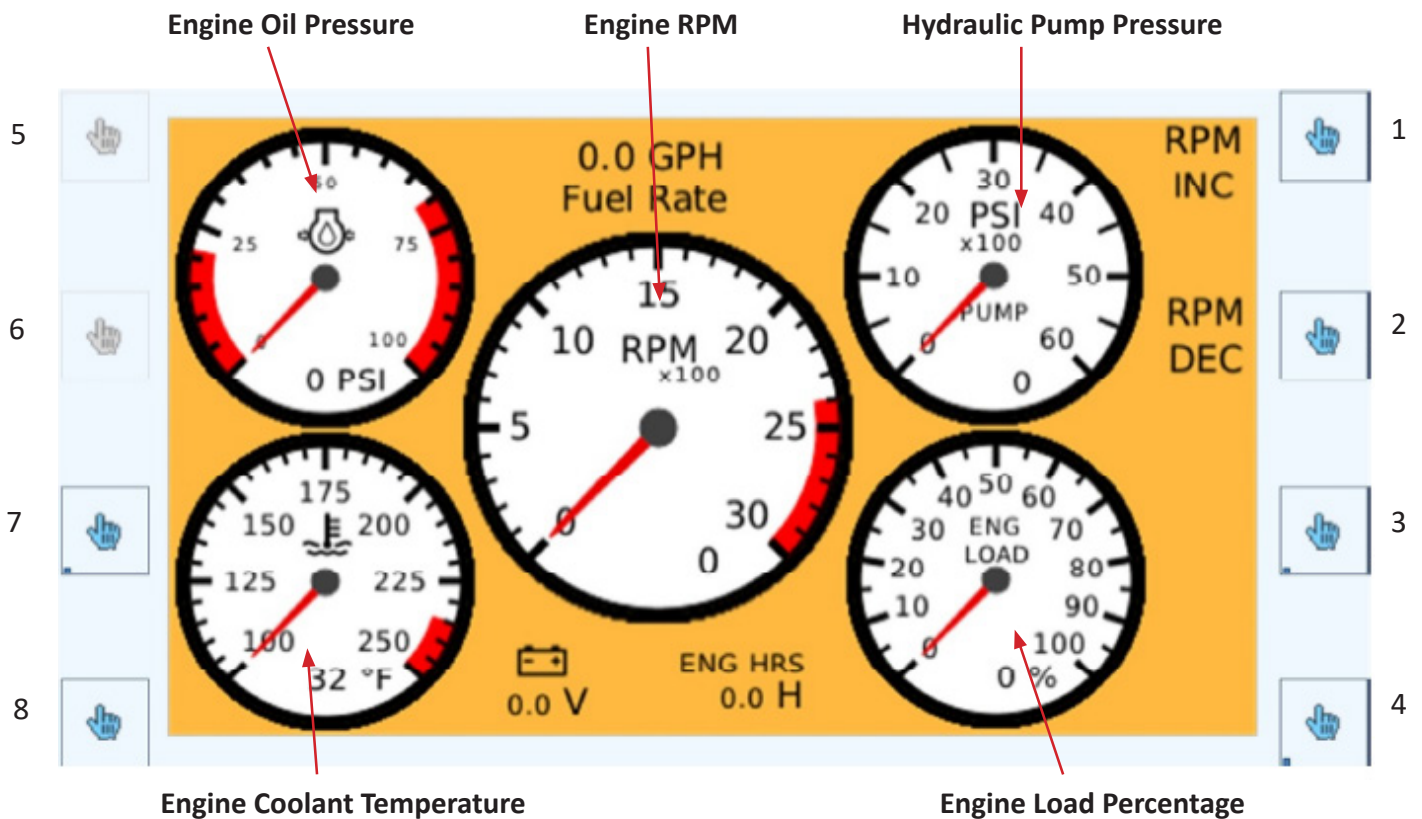

- Button 1 increments engine RPM by 100 RPM up to 1,800 RPM maximum. Holding button jumps to maximum 1,800 RPM.
- Button 2 decrements engine RPM by 100 RPM down to 800 RPM minimum. Holding button jumps to minimum 800 RPM.
- Buttons 3 & 7 change to HPU Diagnostics screen.
- Button 8 changes to Main Menu screen
- Button 4 displays Popup Menu. Press Button 4 again for Popup Menu to include Day/Night toggle (toggle with Button 1).

# CONTROL PANEL OPERATIONS

## Diagnostic Screen

Screen displays status of Pressure Filter, Case Drain Filter, Return Filter, Temperature Switch, Low Oil Level Switch, and Shutdown Oil Level Switch. Status displays 'OK' for each sensor when in a normal state. Status shows red symbol when not in a normal state (tripped)

GENERAL INFORMATION

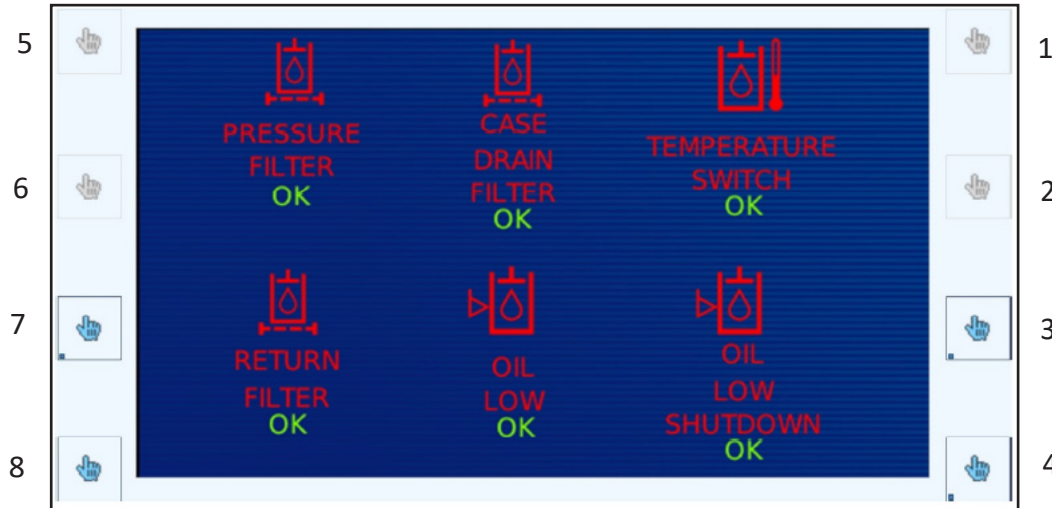

- Buttons 3 & 7 change to Gauge screen.
- Button 8 changes to Main Menu screen
- Button 4 displays Popup Menu. Press Button 4 again for Popup Menu to include Day/Night toggle (toggle with Button 1).

## Control Screen

This screen is reached through the Main Menu. In the Main Menu, Press Button 1 labeled Hydraulic Controls to reach this screen. This screen is not intended for regular use but for when the handheld controller is unusable.

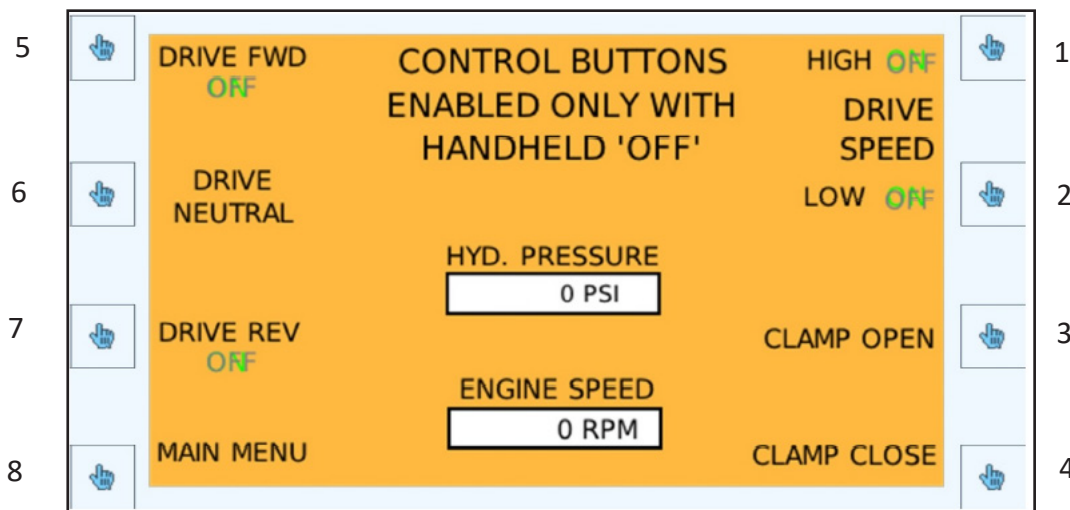

- Button 5 sets system in Drive Forward mode with fixed low speed setting.
- Button 6 sets system in Drive Reverse mode with fixed low speed setting.



# CONTROL TRANSMITTER INFORMATION

## Multi-Function Handheld Transmitter OPTIONAL

### Care and Handling

Failure to follow care and handling instructions will void the warranty and could result in unsafe equipment operation.

- Clean transmitter gently with a damp cloth or dry, compressed air.
- Do not immerse transmitter in water, or spray with hose.
- Do not store outside.
- Do not drop transmitter or otherwise subject transmitter to physical shock.
- Do not expose transmitter to extreme temperatures.
- Do not open transmitter enclosure. Transmitter contains no user serviceable parts.

### Batteries

This transmitter operates from 3 “AA” cell batteries. Long-range transmitters operate from 4 “AAA” batteries. Alkaline batteries generally provide longest life. If rechargeable batteries are used, NiMH type are recommended. Batteries are accessible by removing the thumbscrews that hold the battery compartment door on the back of the housing. No tools are needed to replace batteries. To ensure maximum battery life, be sure to turn the transmitter OFF when not in use. Remove batteries prior to shipping or storing transmitter.

### Operations

Transmitters are built-to-suit, and may be equipped with potentiometers, pushbuttons, switches, and other customer specified controls. Take time to familiarize the operation and arrangement of the controls before operating equipment.

### Transmitter/Receiver Matching

Transmitters and receivers are shipped from the factory as matched pairs. If a new transmitter is to be used, it must be trained to operate the receiver.

#### Training procedure:

##### Transmitters with tether cables:

1. Connect transmitter to receiver using tether cable provided.
2. Operate transmitter to verify tether is connected.
3. Disconnect tether, and resume normal operation.

##### Transmitters without tether cables:

1. Power on transmitter and receiver.
2. Press “LEARN” button on receiver.
3. Operate transmitter normally.

# CONTROL TRANSMITTER OVERVIEW

## Multi-Function Handheld Transmitter Overview

GENERAL INFORMATION

### POWER ON

**TOGGLE POWER SWITCH**  
Press and hold toggle switch up until Power status lights turns on.  
**NOTE:** Status light turns on then continues to blink

### POWER / EMERGENCY STOP

#### **ATTENTION:**

**WILL SHUT OFF ENGINE, DISENGAGE DRIVE AND ALL VALVES INSTANTLY.**  
Control panel will stay on.

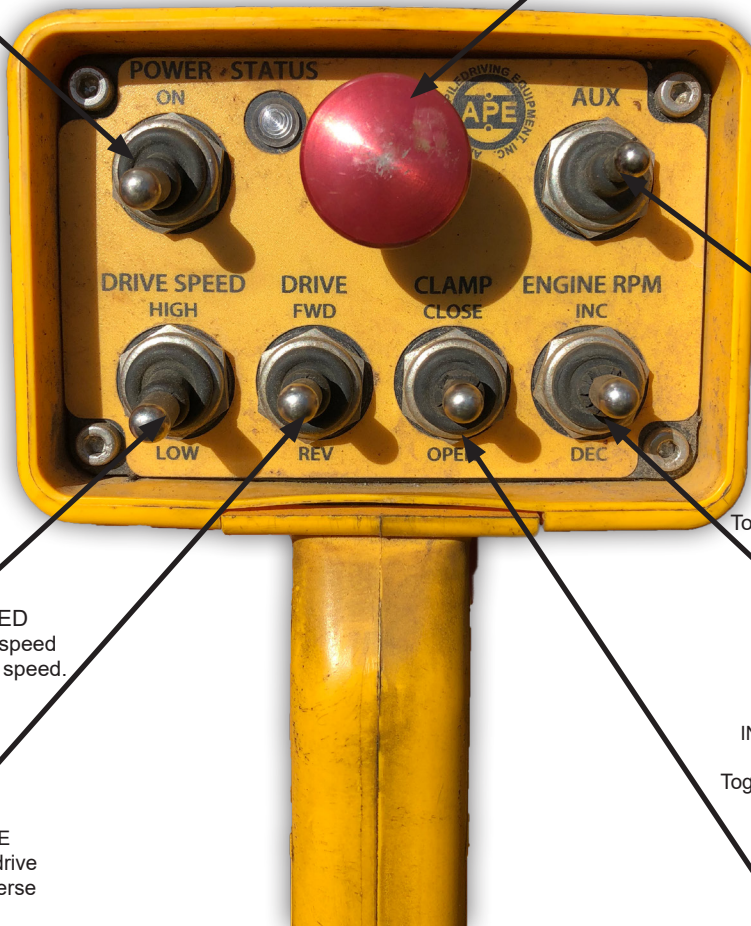

### DRIVE SPEED HIGH

**TOGGLE HIGH AND LOW SPEED**  
Toggle switch up to activate High speed  
Toggle switch down to active Low speed.

### DRIVE FWD / REV

**TOGGLE FORWARD AND REVERSE**  
Toggle switch up activate forward drive  
Toggle switch down to activate reverse drive

**AUX**  
**TOGGLE AUX ON/OFF**  
Toggle switch up to activate Aux line  
Toggle switch down to deactivate Aux line

**ENGINE RPM**  
**INCREASE AND DECREASE ENGINE RPM**  
Toggle switch up to increase engine rpm  
Toggle switch down to decrease engine rpm

**CLAMP FUNCTION**  
**CLAMP CLOSE AND CLAMP OPEN**  
Toggle switch up to close clamp  
Toggle switch down to open clamp

**NOTE: "WHILE DRIVING"** If remote is out of range, Drive will go into neutral, Engine rpm will decrease to idle, and if clamp is active, clamp will stay closed.



# MAINTENANCE

## Maintenance Chart

DAILY	WEEKLY	250 HOURS OR 6 MONTHS	1500 HOURS OR 1 YEAR	6000 HOURS OR 2 YEARS	6000 HOURS OR 3 YEARS
<ul style="list-style-type: none"> <li>• Check operator's report</li> <li>• Check oil and bring to correct level</li> <li>• Check coolant and bring to correct level</li> <li>• Visually inspect fan</li> <li>• Visually inspect engine for damage, leaks, loose or frayed belts and correct or record for future action</li> <li>• Drain fuel-water separator</li> </ul>	<ul style="list-style-type: none"> <li>• Check air intake system for wear points or damage to piping, loose clamps, and leaks.</li> <li>• Check air cleaner restriction</li> <li>• Check and clean air cleaner element</li> <li>• Drain moisture from tanks</li> </ul>	<ul style="list-style-type: none"> <li>• Change lubricating oil</li> <li>• Change lubricating oil filters</li> <li>• Change fuel filter</li> <li>• Clean crankcase breather</li> <li>• Check engine coolant concentration level</li> <li>• Replace final fuel filter/clean primary fuel filter. Drain water from fuel tank</li> <li>• Inspect/replace alternator fan and accessory drive belts</li> <li>• Inspect/replace hoses and clamps</li> <li>• Lubricate fan drive bearings</li> <li>• Clean/check battery electrolyte level</li> </ul>	<ul style="list-style-type: none"> <li>• Adjust valves and injectors</li> <li>• Steam clean engine</li> <li>• Check torque on turbocharger mounting nuts</li> <li>• Check torque on engine mounting bolts</li> <li>• Replace hoses as required</li> <li>• Check/adjust engine valve lash</li> <li>• Check/adjust low idle speed</li> <li>• Test/exchange fuel injection nozzles</li> <li>• Inspect/rebuild alternator</li> </ul>	<ul style="list-style-type: none"> <li>• Clean cooling system and change coolant and antifreeze</li> <li>• Inspect Temperature regulator</li> <li>• Inspect/rebuild turbocharger</li> <li>• Inspect/rebuild starter</li> </ul>	<ul style="list-style-type: none"> <li>• Clean and calibrate the following:               <ul style="list-style-type: none"> <li>• -Injectors</li> <li>• -Fuel pump</li> <li>• -Fan Clutch</li> <li>• -Water pump</li> <li>• -Fan Hub</li> <li>• -Fan idler pulley assembly</li> <li>• -Vibration dampener</li> </ul> </li> </ul>

Follow the manufacturer's recommended maintenance procedures for the starter, alternator, batteries, electrical components, and fan clutch.

At each scheduled maintenance interval preform all previous checks which are due for scheduled maintenance.



### Engine Oil

Change engine oil every 250 hours or 6 months, whichever occurs first. Oil should be replaced with Caterpillar 15W-40.

### Engine Oil Filter

Change engine oil filter every 250 hours or 6 months, whichever occurs first. Only Cat filters should be used. Any other filters will cause damages to the engine, fees will apply, warranty will be voided.

### Hydraulic Oil

When adding or changing hydraulic fluid, APE uses only Biodegradable Envirologic 146 hydraulic fluid, which is not-toxic and will not harm soil or water, and is biodegradable. Consult your local oil supplier for recommendations on mixing hydraulic oils. Change hydraulic oil if it looks milky; this is an indication that water or other contamination may have occurred.

NOTE: Current Hydraulic Oil Type:

### Envirologic Hydraulic 146

### Air Cleaner Replacement

Check and clean the air cleaner weekly. If the air cleaner needs to be replaced, replace only with Caterpillar filter. Warranty may be void using other filters.

### Return Filter Elements

Change all filters every 500 working hours, 2 years or when indicated dirty, whichever occurs first. To change the return filter element follow the steps below:

1. Shut down power unit.
2. Place warning tag on control panel so that the power unit is not started while filters are being replaced.
3. Disconnect negative battery cable.
4. Clean area around filters so that when they are removed there is no chance of introducing dirt into the hydraulic system.
5. Using a 1-1/4 wrench or socket, turn the filter counter-clockwise and spin the filter element off the filter housing.
6. Install new clean filter making sure the spring and o-ring are in the proper place.



Preventative maintenance includes normal servicing that will keep the power unit in peak operative condition and prevent unnecessary trouble from developing. This servicing consists of periodic lubrication and inspection of moving parts and accessories of the unit.

Lubrication is an essential part of preventative maintenance controlling, to a great extent, the useful life of the unit. Different lubricants are needed and some components in the unit require more frequent lubrication than others. Therefore, it is important that the instructions regarding types of lubricants and frequency of their application be closely followed.

To prevent minor irregularities from developing into serious conditions that might involve shutdown and major repair, several other services or inspections are recommended for the same intervals as the periodic lubrications. The purpose of these services or inspections is to assure the uninterrupted operation of the unit.

- Thoroughly clean all lubrication fittings, caps, filler and level plugs along with their surrounding surfaces before servicing
- Prevent dirt from entering in with lubricants and coolants

The intervals given in the schedule are based upon normal operation.

Perform these services, inspections, etc., more often as needed for operation under abnormal or severe conditions.

### Storage

During short-term storage of a power unit, the following should be taken into consideration:

- Cover any pressure openings and open threaded holes with suitable caps
- Protect the unpainted surfaces from dirt and moisture
- The power unit should not be stored in an area with substances that have an aggressive corrosive nature; i.e., solvents, acids, alkalies and/or salts

For long-term storage (over 9 months), the following additional actions are recommended:

- Damages to surface paint must be repaired before item is stored
- Protect the unpainted surfaces with suitable anti-corrosion treatment such as CRC SP-350, CorrosionX corrosion inhibitor, or WD-40 Long Term Corrosion Inhibitor
- Fill the power unit completely with hydraulic fluid



If these instructions are followed to the letter, the power unit may be stored for approximately 2-years. However, as storage conditions do have a significant effect, all suggested time frames should be considered as guide values only.

# TROUBLESHOOTING

## Understanding the Hydraulic System



***It is imperative that the hydraulic fluid is kept clean to a minimum ISO Code***

***17/15/11***

***New hydraulic fluid is NOT clean oil***

\*See attached document “Understanding ISO Codes” under the Reference / Notes Section\*

\*See Warranty document regarding fluid cleanliness at the beginning of this manual\*

Bulk oil does not typically meet the cleanliness standards required by APE equipment.

### For Power Units Powering Helical Drills

- Pressure filters: Clean the hydraulic fluid going to the drill motor and manifold in the forward and reverse directions.
- M1/M2                      DRIVE
- LS                              LOAD SENSE
- 10/11: RDFA-LCN is a direct acting relief valve that is used to protect hydraulic components from pressure variants.
- 8/16/5/19                  COILS
- T1 / PD: Both of these ports return to tank.

### Electrical System

The electrical system is a normally closed circuit, and runs a self diagnostic test when the panel is powered on. If there is a fault in the electrical system an error screen will appear on the control panel display.

# SCHEMATIC

## Hydraulic Schematic

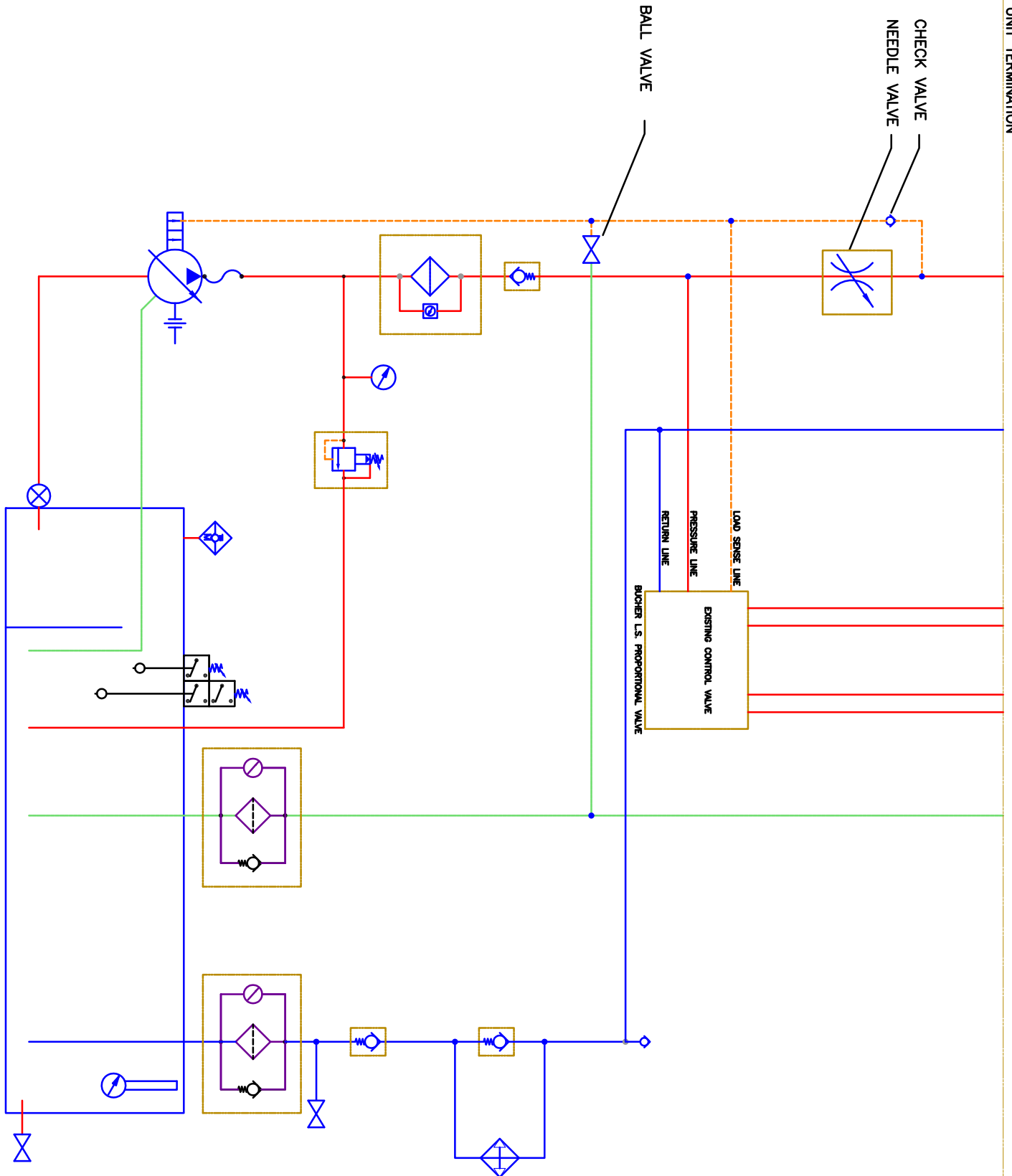

POWER UNIT TERMINATION

TROUBLE SHOOTING





# DIAGRAM

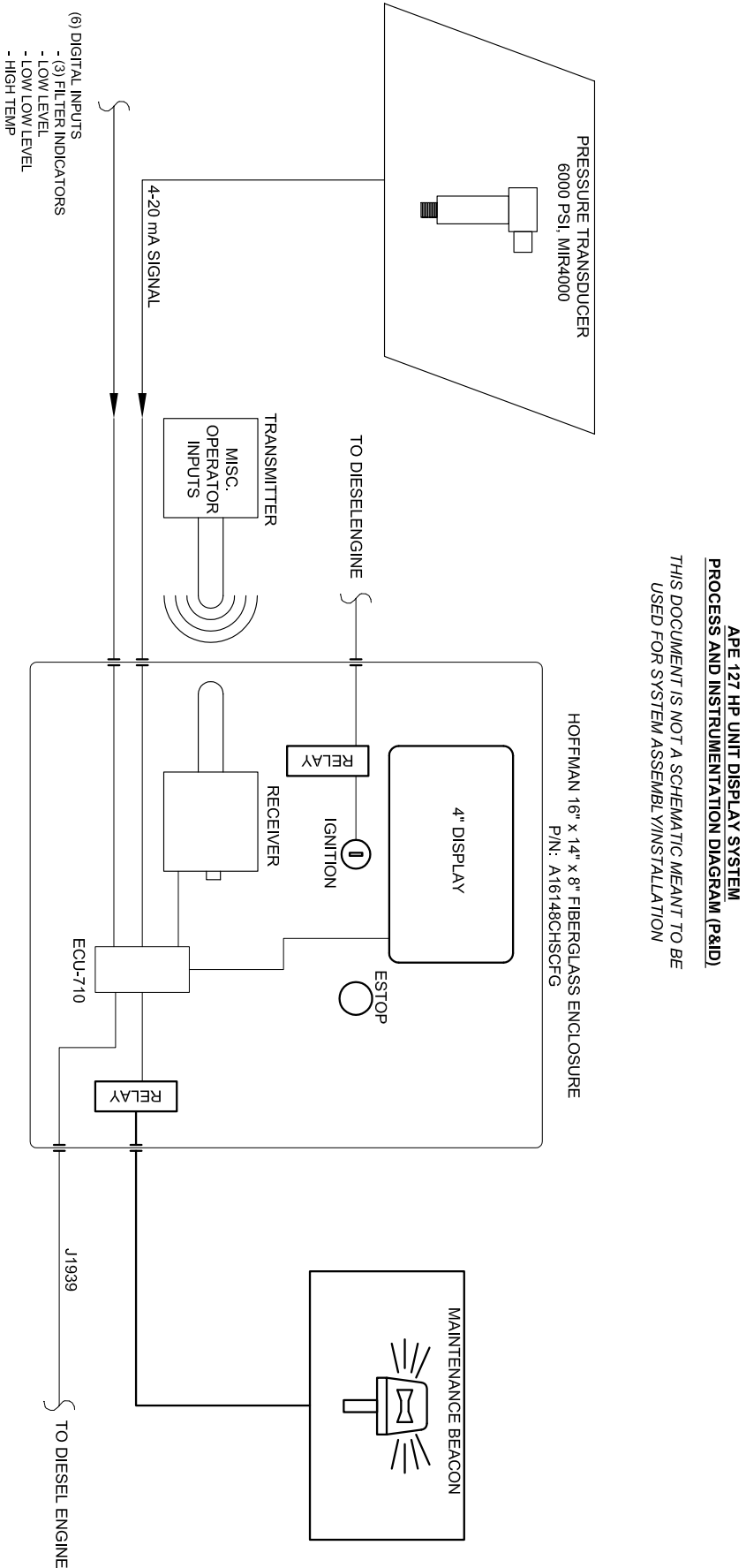

## TROUBLE SHOOTING



# ELECTRICAL SCHEMATIC

TROUBLE SHOOTING

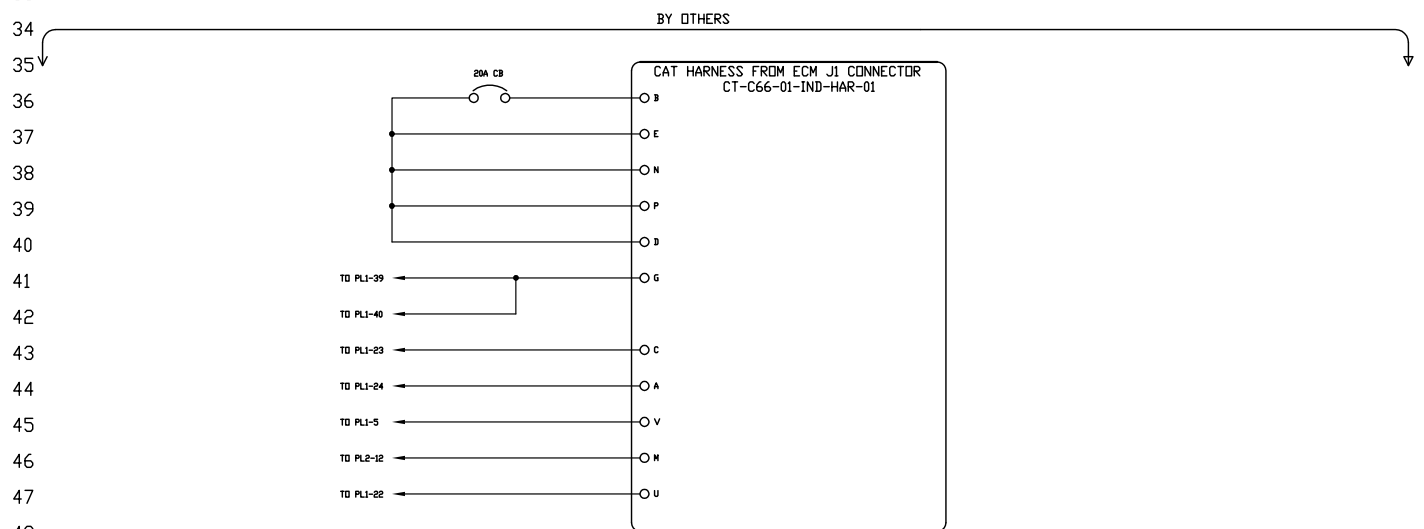
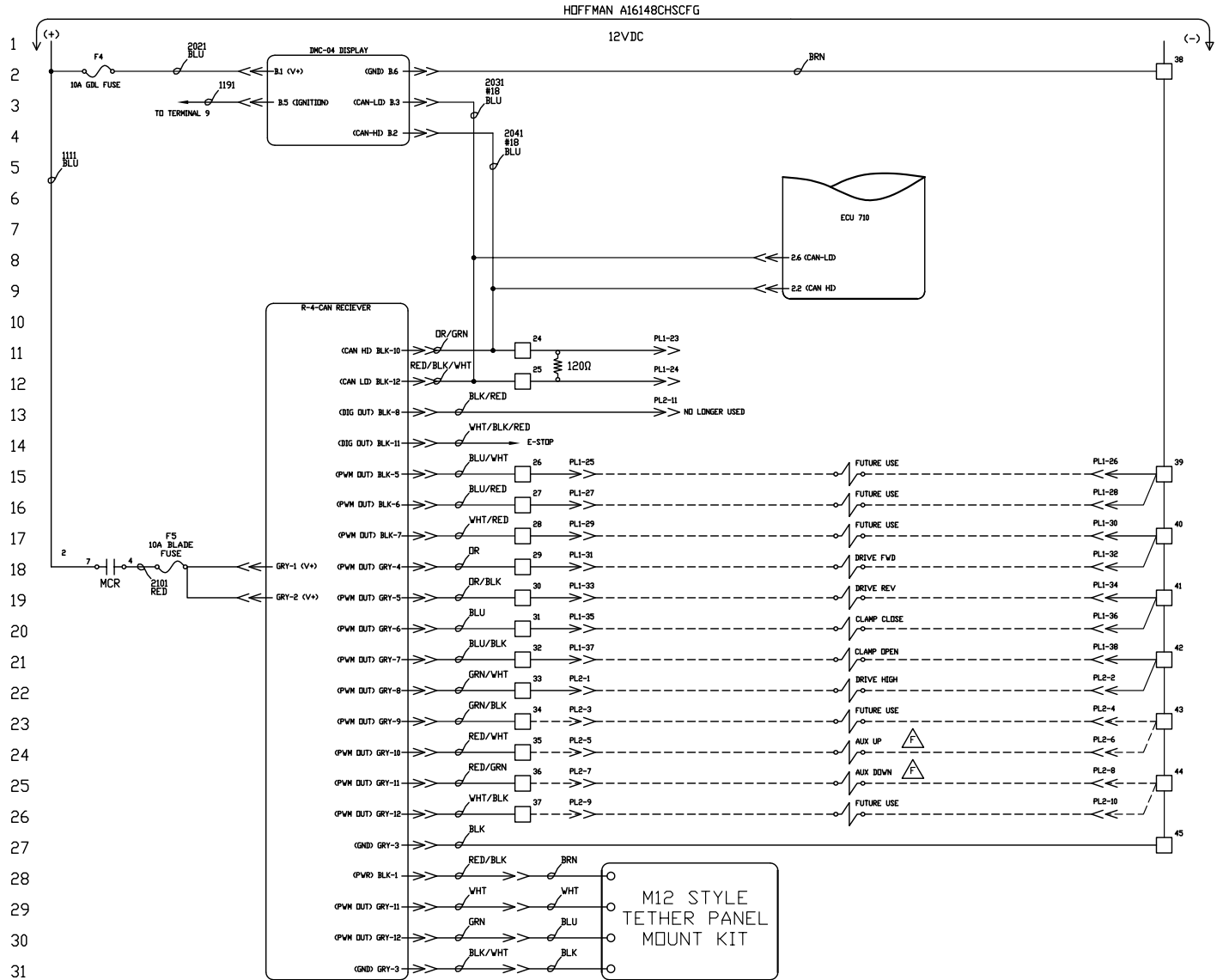

# HANDHELD TROUBLESHOOTING

## Multi-Function Handheld Transmitter Troubleshooting

ISSUE	SOLUTIONS
<i>Transmitter not working. LED not on or blinking.</i>	<i>Install new batteries. Make sure power switch is on.</i>
<i>Transmitter not working. LED on or blinking.</i>	<i>Make sure E-Stop switch is out (if equipped.) Install new batteries. Make sure receiver is powered. Check receiver fuse. Make sure transmitter is in range of receiver. Make sure transmitter and receiver are matched.</i>
<i>Poor range.</i>	<i>Check receiver antenna and cable for loose connections or damage. Reinstall new batteries. Obstructions, interference, and adverse weather can affect range.</i>
<i>One or more functions do not operate properly.</i>	<i>Verify receiver wiring is correct. Verify control device is operational (solenoid valve, pump, etc.) Inspect transmitter, receiver, and cabling for damage. (Do not open.) Some control systems feature special program logic that can disable functions under certain conditions. Consult factory for specific details.</i>



# PROGRAMMING

## Setting up the Program

Prior to any program updates you will need:

1. A blank flash drive
2. A laptop with Plus + One Service guide software installed  
<http://www2.powersolutions.danfoss.com/l/38972/2016-05-30/525qvt>
3. CAN to USB adapter P/N 1001190

To update the program you must first download and format the flash drive as follows:

1. Insert blank USB into your laptop.
  - a. Format USB by going to:
  - b. My computer
  - c. Right click on flash drive
  - d. Click on format and format as shown in the figure to the right.
2. Download all files from link provided
3. Extract all downloaded files onto USB drive.
4. All files in the folder labeled "**Display Program**" must be moved out of the folder or the update will not work.
5. On the bottom right of the screen eject USB to prevent any file corruption.

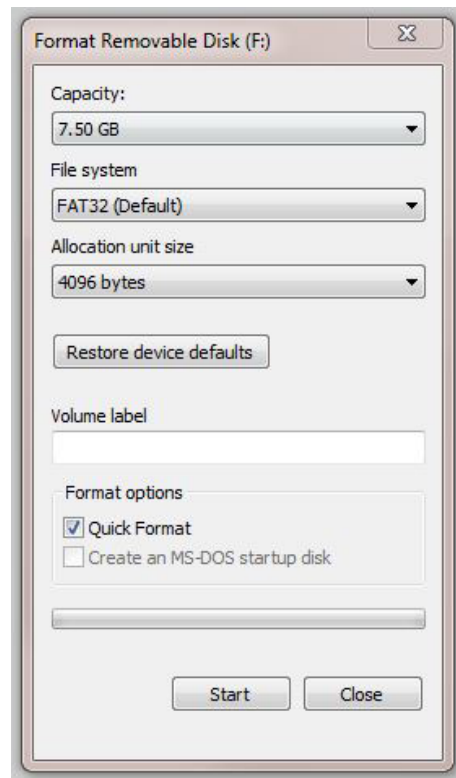

# REPLACEMENT PARTS

## Common Replacement Parts

LOCATION	ENGINE	PART NUMBER	APE PART NUMBER	QUANTITY
Engine Oil Filter Element	C4.4	7W-2326	1005590	1
Fuel Filter/Water Separator	C4.4	308-7298	1005862A	1
Engine Fuel Filter	C4.4	299-8229	1005861	1
Inner Air Filter Element	C4.4	206-5235	1005863	1
Outer Air Filter Element	C4.4	206-5234	1005864	1
Recirculation Filter Element	C4.4	KKZ10	1001514	1
Return Filter Element	C4.4	KKZ10	1001514	2
Hand pump Fill Filter Element	C4.4	AE-25	521041	1

LOCATION	ENGINE	OIL TYPE	APE PART NUMBER	CAPACITY
Engine Oil	C4.4	Caterpillar DELO 15W-40	513001-15W40-D400-1	5.3-7.3 Quarts
Engine Coolant	C4.4	Caterpillar DEAC Antifreeze	513001-ANTI-A DEAC-1	Contact APE Service
Fuel	C4.4	Diesel Fuel	100725B	60 Gal
Hydraulic Oil	C4.4	Envirollogic 146	513001	160 Gal

DESCRIPTION	PART NUMBER	APE PART NUMBER	QUANTITY
Fuel Level Sensor	W392675	1006733	1
ACT Hydraulic Level Sensor	C-520- HI/LOW	CONTACT APE	1
Schroeder Indicator Sending Unit	MS19SSNC-75	1006992	1
Inserta Check Valves	INSERTA ICFT-A-6224-N-15	CONTACT APE	1
Inserta Check Valve body	INSERTA ICF-B-61-24	CONTACT APE	1
Inserta Slip-in Check Valves	INSERTA ICF-C-32-N-07	CONTACT APE	1

DESCRIPTION	ENGINE	PART NUMBER	APE PART NUMBER
Battery	C4.4	31P-MHD	400890
Fan Belt	C4.4	314-2310	Contact APE Service
Hydraulic Sight Gauge 6"	C4.4	G607-06-A-1-4-513003	513003
Fuel Level Gauge	C4.4	8680-01028	513050
HPS Control Panel	C4.4	D13033	Contact APE Service
Dmic 65PSI Check Valve	C4.4	CVH0651250S	Contact APE Service
DMIC 1 1/2" CODE 62 CHECK VALVE	C4.4	CVDM3015FKU1111	Contact APE Service
BUCHER CONTROL VALVE	C4.4	LVS12-OO4D5YT42C00B-BB	Contact APE Service
Hydraulic Tank Breather / Hydac	C4.4	BFP30U3W1.0/RV0.4	1003556

REPLACEMENT PARTS



# MANIFOLD

## BUCHER 2 SPOOL DIRECTIONAL VALVE ASSEMBLY

P/N: LVS12-004D5YT42C00B-BB



REPLACEMENT PARTS

APE PART NUMBER	DESCRIPTION	QTY
CONTACT APE	2 SPOOL LVS DIRECTIONAL VALVE ASSY.	1
CONTACT APE	LVS-E-CF2-U100A00	1
CONTACT APE	LVS12-004D5YT42C00B-BB	2
CONTACT APE	LVS-A-CA*.****A00	1





# ARRANGEMENTS

## Cooler Arrangement

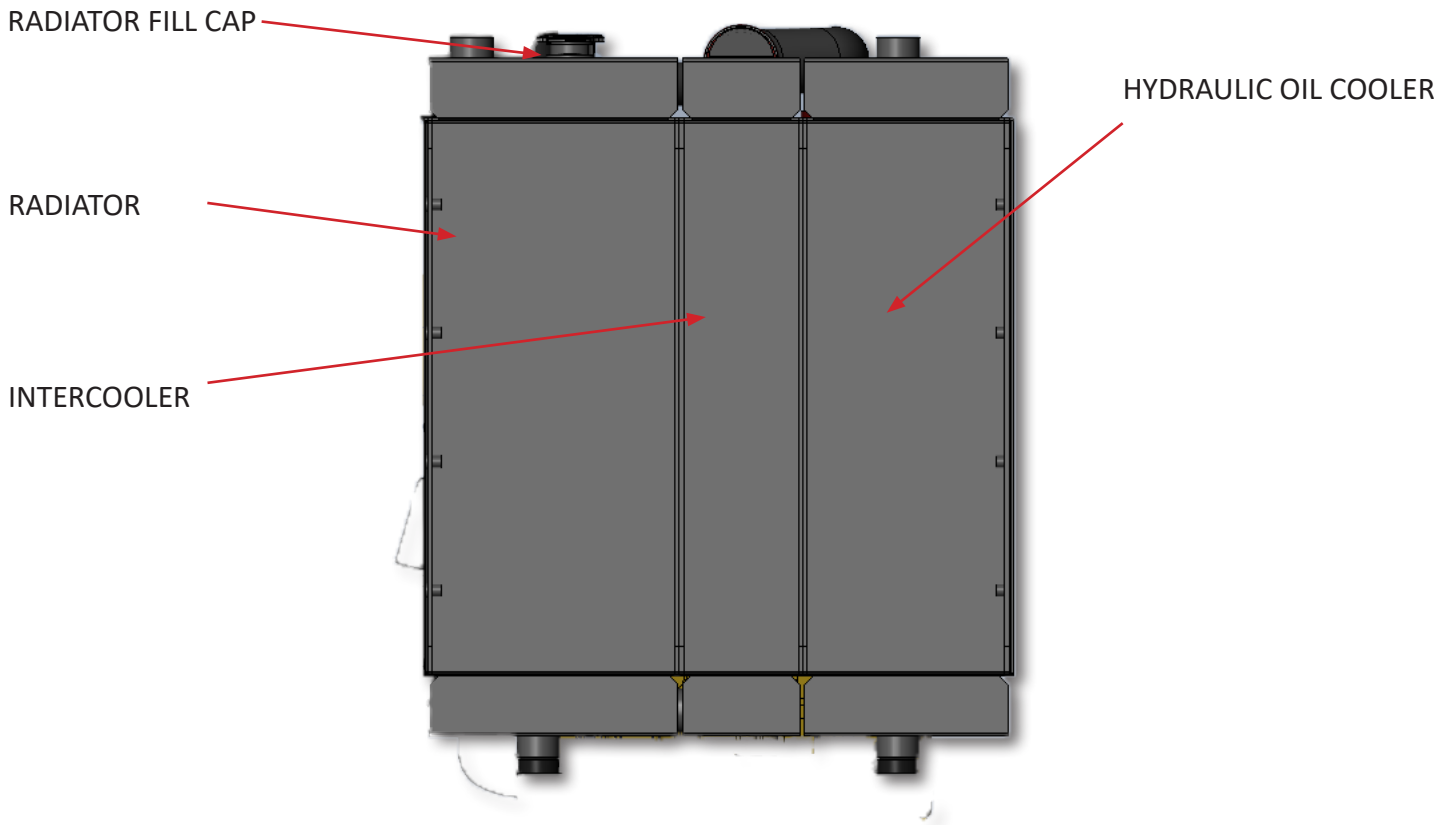

## Pump Arrangement

P/N: PV140R1G3T1NWCC

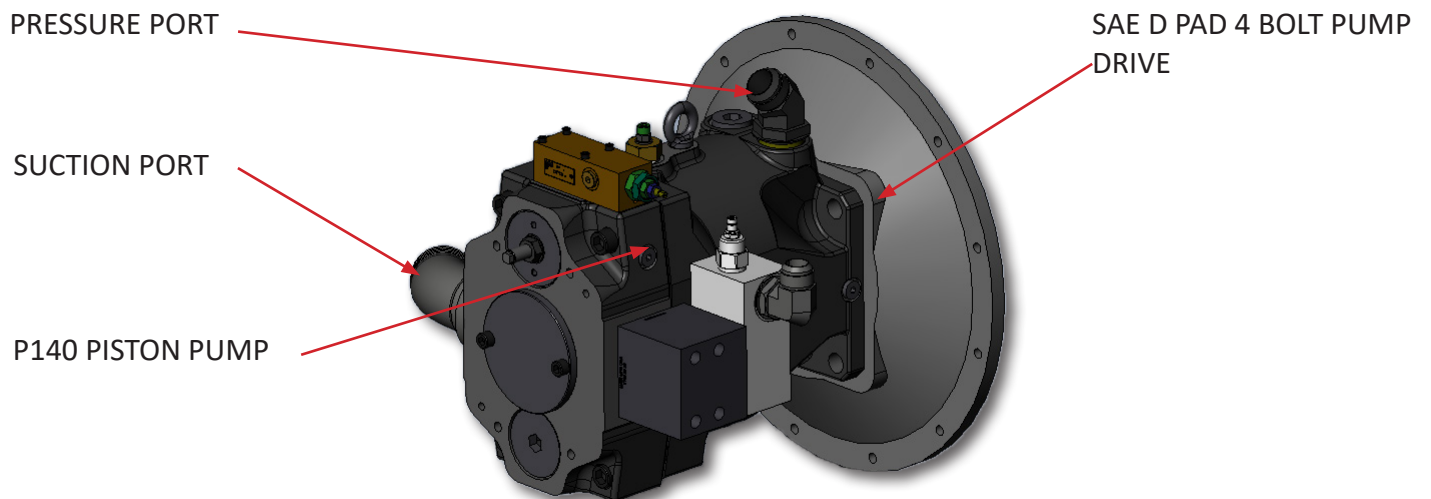

# REFERENCE / NOTES

## UNDERSTANDING ISO CODES

The ISO cleanliness code is used to quantify particulate contamination levels per milliliter of fluid at 3 sizes 4μ[c], 6μ[c], and 14μ[c]. The ISO code is expressed in 3 numbers (ie 19/17/14). Each number represents a contaminant level code for the correlating particle size. The code includes all particles of the specified size and larger. It is important to note that each time a code increases the quantity range of particles is doubling.

ISO 4406 Chart		
Range Code	Particles per milliliter	
	More than	Up to/including
24	80000	160000
23	40000	80000
22	20000	40000
21	10000	20000
20	5000	10000
19	2500	5000
18	1300	2500
17	640	1300
16	320	640
15	160	320
14	80	160
13	40	80
12	20	40
11	10	20
10	5	10
9	2.5	5
8	1.3	2.5
7	0.64	1.3
6	0.32	0.64

Sample 1 (see photo 1)

Particle Size	Particles per ml*	ISO 4406 Code range	ISO Code
4μ[c]	151773	80000~160000	24
6μ[c]	38363	20000~40000	22
10μ[c]	8229		
14μ[c]	3339	2500~5000	19
21μ[c]	1048		
38μ[c]	112		

Sample 2 (see photo 2)

Particle Size	Particles per ml*	ISO 4406 Code range	ISO Code
4μ[c]	492	320 ~ 640	16
6μ[c]	149	80 ~ 160	14
10μ[c]	41		
14μ[c]	15	10 ~ 20	11
21μ[c]	5		
38μ[c]	1		

Photo 1

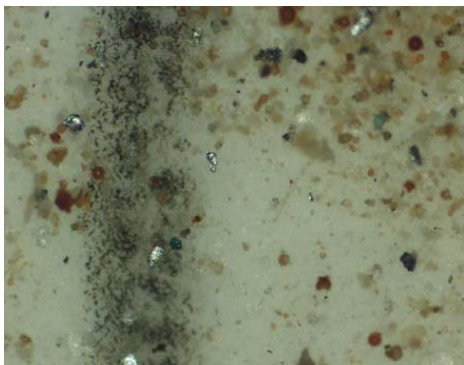

Photo 2



REFERENCE / NOTES

# TARGET ISO CLEANLINESS CODES

When setting target ISO fluid cleanliness codes for hydraulic and lubrication systems it is important keep in mind the objectives to be achieved. Maximizing equipment reliability and safety, minimizing repair and replacement costs, extending useful fluid life, satisfying warranty requirements, and minimizing production down-time are attainable goals. Once a target ISO cleanliness code is set following a progression of steps to achieve that target, monitor it, and maintain it justifiable rewards will be yours.

### Set the Target.

The first step in identifying a target ISO code for a system is to identify the most sensitive on an individual system, or the most sensitive component supplied by a central reservoir. If a central reservoir supplies several systems the overall cleanliness must be maintained, or the most sensitive component must be protected by filtration that cleans the fluid to the target before reaching that component.

### Other Considerations

Table 1 recommends conservative target ISO cleanliness codes based on a several component manufacturers guidelines and extensive field studies for standard industrial operating conditions in systems using petroleum based fluids. If a non-petroleum based fluid is used (i.e. water glycol) the target ISO code should be set one value lower for each size (4 μ[c]/6μ[c]/14μ[c]). If a combination of the following conditions exists in the system the target ISO code should also be set one value lower:

- Component is critical to safety or overall system reliability.
- Frequent cold start.
- Excessive shock or vibration.
- Other Severe operation conditions.

### Recommended\* Target ISO Cleanliness Codes and media selection for systems using petroleum based fluids per ISO4406:1999 for particle sizes 4μ[c] / 6μ[c] / 14μ[c]

	Pressure < 140 bar < 2000 psi	Media βx[c] = 1000 (βx = 200)	Pressure 212 bar 3000 psi	Media βx[c] = 1000 (βx = 200)	Pressure > 212 bar > 3000 psi	Media βx[c] = 1000 (βx = 200)
<b>Pumps</b>						
Fixed Gear	20/18/15	22μ[c] (25 μ)	19/17/15	12μ[c] (12 μ)	-	-
Fixed Piston	19/17/14	12μ[c] (12 μ)	18/16/13	12μ[c] (12 μ)	17/15/12	7μ[c] (6 μ)
Fixed Vane	20/18/15	22μ[c] (25 μ)	19/17/14	12μ[c] (12 μ)	18/16/13	12μ[c] (12 μ)
Variable Piston	18/16/13	7μ[c] (6 μ)	17/15/13	5μ[c] (3 μ)	16/14/12	7μ[c] (6 μ)
Variable Vane	18/16/13	7μ[c] (6 μ)	17/15/12	5μ[c] (3 μ)	-	-
<b>Valves</b>						
Cartridge	18/16/13	12μ[c] (12 μ)	17/15/12	7μ[c] (6 μ)	17/15/12	7μ[c] (6 μ)
Check Valve	20/18/15	22μ[c] (25 μ)	20/18/15	22μ[c] (25 μ)	19/17/14	12μ[c] (12 μ)
Directional (solenoid)	20/18/15	22μ[c] (25 μ)	19/17/14	12μ[c] (12 μ)	18/16/13	12μ[c] (12 μ)
Flow Control	19/17/14	12μ[c] (12 μ)	18/16/13	12μ[c] (12 μ)	18/16/13	12μ[c] (12 μ)
Pressure Control (modulating)	19/17/14	12μ[c] (12 μ)	18/16/13	12μ[c] (12 μ)	17/15/12	7μ[c] (6 μ)
Proportional Cartridge Valve	17/15/12	7μ[c] (6 μ)	17/15/12	7μ[c] (6 μ)	16/14/11	5μ[c] (3 μ)
Proportional Directional	17/15/12	7μ[c] (6 μ)	17/15/12	7μ[c] (6 μ)	16/14/11	5μ[c] (3 μ)
Proportional Flow Control	17/15/12	7μ[c] (6 μ)	17/15/12	7μ[c] (6 μ)	16/14/11	5μ[c] (3 μ)
Proportional Pressure Control	17/15/12	7μ[c] (6 μ)	17/15/12	7μ[c] (6 μ)	16/14/11	5μ[c] (3 μ)
Servo Valve	16/14/11	7μ[c] (6 μ)	16/14/11	5μ[c] (3 μ)	15/13/10	5μ[c] (3 μ)
<b>Bearings</b>						
Ball Bearing	15/13/10	5μ[c] (3 μ)	-	-	-	-
Gearbox (industrial)	17/16/13	12μ[c] (12 μ)	-	-	-	-
Journal Bearing (high speed)	17/15/12	7μ[c] (6 μ)	-	-	-	-
Journal Bearing (low speed)	17/15/12	7μ[c] (6 μ)	-	-	-	-
Roller Bearing	16/14/11	7μ[c] (6 μ)	-	-	-	-
<b>Actuators</b>						
Cylinders	17/15/12	7μ[c] (6 μ)	16/14/11	5μ[c] (3 μ)	15/13/10	5μ[c] (3 μ)
Vane Motors	20/18/15	22μ[c] (25 μ)	19/17/14	12μ[c] (12 μ)	18/16/13	12μ[c] (12 μ)
Axial Piston Motors	19/17/14	12μ[c] (12 μ)	18/16/13	12μ[c] (12 μ)	17/15/12	7μ[c] (6 μ)
Gear Motors	20/18/14	22μ[c] (25 μ)	19/17/13	12μ[c] (12 μ)	18/16/13	12μ[c] (12 μ)
Radial Piston Motors	20/18/15	22μ[c] (25 μ)	19/17/14	12μ[c] (12 μ)	18/16/13	12μ[c] (12 μ)
<b>Test Stands, Hydrostatic</b>						
Test Stands	15/13/10	5μ[c] (3 μ)	15/13/10	5μ[c] (3 μ)	15/13/10	5μ[c] (3 μ)
Hydrostatic Transmissions	17/15/13	7μ[c] (6 μ)	16/14/11	5μ[c] (3 μ)	16/14/11	5μ[c] (3 μ)

\*Depending upon system volume and severity of operating conditions a combination of filters with varying degrees of filtration efficiency might be required (i.e. pressure, return, and off-line filters) to achieve and maintain the desired fluid cleanliness.

Example	ISO Code	Comments
Operating Pressure	156 bar, 2200 psi	
Most Sensitive Component	Directional Solenoid	19/17/14 recommended baseline ISO Code
Fluid Type	Water Glycol	18/16/13 Adjust down one class
Operating Conditions	Remote location, repair difficult High ingress rate	17/15/12 Adjust down one class, combination of critical nature, severe conditions



Torque-Tension Relationship for ASTM A574 Socket Head Cap Screws

Nominal Dia (in.)	Unified Coarse Thread Series						Fine Thread Series					
	threads per inch	Tensile Stress Area (sq. in.)	Clamp Load (lbs)	Tightening Torque			threads per inch	Tensile Stress Area (sq. in.)	Clamp Load (lbs)	Tightening Torque		
				K = 0.15 (ft-lbs)	K = 0.16 (ft-lbs)	K = 0.20 (ft-lbs)				K = 0.15 (ft-lbs)	K = 0.16 (ft-lbs)	K = 0.20 (ft-lbs)
1/4	20	0.0318	3341	10	11	14	28	0.0364	3819	12	13	16
5/16	18	0.0524	5505	22	23	29	24	0.0581	6097	24	25	32
3/8	16	0.0775	8136	38	41	51	24	0.0878	9222	43	46	58
7/16	14	0.1063	11162	61	65	81	20	0.1187	12465	68	73	91
1/2	13	0.1419	14899	93	99	124	20	0.1600	16795	105	112	140
5/8	11	0.2260	22883	179	191	238	18	0.2560	25916	202	216	270
3/4	10	0.3345	33864	317	339	423	16	0.3730	37762	354	378	472
7/8	9	0.4617	46751	511	545	682	14	0.5095	51584	564	602	752
1	8	0.6057	61332	767	818	1022	14	0.6799	68839	860	918	1147
1 1/8	7	0.7633	77282	1087	1159	1449						
1 1/4	7	0.9691	98123	1533	1635	2044	12	1.0729	108636	1697	1811	2263
1 3/8	6	1.1549	116932	2010	2144	2680	12	1.3147	133115	2288	2440	3051
1 1/2	6	1.4053	142282	2668	2846	3557	12	1.5810	160079	3001	3202	4002
1 3/4	5	1.8995	192320	4207	4487	5609						
2	4.5	2.4982	252945	6324	6745	8432						

Clamp load calculated as 75% of the proof load for socket head cap screws as specified in ASTM A574.

Torque values calculated from formula  $T = KDF$ , where

K = 0.15 for "lubricated" conditions, K = 0.16 "as-received" and K = 0.20 for "dry" conditions

D = Nominal Diameter

F = Clamp Load

**Caution:** All material included in this chart is advisory only, and its use by anyone is voluntary. In developing this information, Fastenal has made a determined effort to present its contents accurately. Extreme caution should be used when using a formula for torque/tension relationships. Torque is only an indirect indication of tension. Under/over tightening of fasteners can result in costly equipment failure or personal injury.

[engineer@fastenal.com](mailto:engineer@fastenal.com)

All information given in this Manual is current and valid per the information available at the time of publication. (Please check the updated revision date at the bottom of each page.)

American Piledriving Equipment (APE) reserves the right to implement changes without prior notice.

Please visit [www.americanpiledriving.com](http://www.americanpiledriving.com) for the most recent version of this publication.

AMERICAN PILEDRIVING EQUIPMENT, INC.  
7032 S. 196th Street  
Kent, Washington 98032  
Office: 253-872-0141  
Toll Free: 800-248-8498  
Fax: 253-872-8710



**800-248-8498**  
WWW.AMERICANPILEDRIVING.COM

**MODEL 127 POWER UNIT**

Copyright © 2020 American Piledriving Equipment Inc. All Rights Reserved