



MODEL 220
HYDRAULIC
IMPACT HAMMER

OPERATING AND MAINTENANCE MANUAL

J&M MODEL 220

HYDRAULIC IMPACT HAMMER

WITH MODEL 335 POWER PACK

SERIAL NUMBERS: 484002 AND ABOVE



**J&M FOUNDATION
EQUIPMENT, LLC**

OM-220-325-0296

SPECIALIZING IN PILE DRIVING EQUIPMENT



**MODEL 220
HYDRAULIC
IMPACT HAMMER**



**MODEL 220
HYDRAULIC
IMPACT HAMMER**

PREFACE

This manual was prepared to acquaint the owner, operator and serviceman with the construction, operation and servicing of the J&M Model 220 Hydraulic Impact Pile Hammer and the J&M Model 325 Power Unit. We strongly suggest that this manual be studied carefully and understood by all personnel involved in operating or performing maintenance work on the hammer. J&M equipment is engineered to provide reliable operation and a long servJ&M life under normal operating conditions. Equipment reliability and service life can be improved by following the maintenance procedures in this manual.

This manual is divided into seven sections- Introduction, General information, Preparation for Operation, Operation, Maintenance, Trouble-Shooting and Ordering Parts.

The General Information section contains a brief description of the hammer and specification information.

The Preparation for Operation section contains information about maintenance and other work required before starting the hammer.

The Operation section includes general operating information plus details on hot and cold weather operation.

The Maintenance & Adjustments section contains routine maintenance procedures and instructions for making adjustments and repairs to the hammer.

The Trouble-Shooting section has suggestions for identifying and resolving operating difficulties.

The Ordering Parts section contains information for ordering parts including parts drawings and lists.



**MODEL 220
HYDRAULIC
IMPACT HAMMER**



**MODEL 220
HYDRAULIC
IMPACT HAMMER**

**J&M, LLC.
STANDARD WARRANTY**

J&M, Foundation Equipment, LLC. (J&M) warrants new products sold by it to be free from defects in material and workmanship for a period of 90 days after date of delivery to the first user and subject to the following conditions: J&M's obligation and liability under this warranty is expressly limited to repairing or replacing, at J&M's option, any parts which appear to J&M upon inspection to have been defective in material or workmanship. Such parts shall be provided at no cost to the user at the business establishment of J&M or at the J&M distributor of the product during regular working hours.

This warranty shall not apply to component parts or accessories of products not manufactured by J&M and which carry the warranty of the manufacturer thereof or to normal maintenance parts (such as filters).

Replacement or repair parts installed in the product covered by this warranty are warranted only for the remainder of the warranty as if such parts were original components of said product.

J&M's obligation under this warranty shall not include any transportation charges, costs of installation, duty, taxes or any other charges whatsoever, or any liability for direct, indirect, incidental, or consequential damage or delay.

If requested by J&M, products or parts for which a warranty claim is made are to be returned transportation prepaid to J&M.

Any improper use, including operation after discovery of defective or worn parts, operation beyond rated capacity, substitution of parts not approved by J&M or any alteration or repair by others in such manner as is J&M's judgment affects the product materially and adversely shall void the warranty.

For impact pile hammers, driving in excess of 10 blows per inch (set of 0.1 inch per blow) is considered practical refusal. Driving in excess of 10 blows per inch for more than 6 inches of driving or driving in excess of 20 blows per inch at all is considered improper use and will void the hammer warranty.

For vibratory drivers, driving when penetration is less than 1" per minute is considered practical refusal. Driving when penetration is less than 1" per minute for more than 5 minutes of driving or driving at all when penetration is less than 1" per minute and amplitude is greater than 1" (vibrator and pile are bouncing) is considered improper use and will void the vibrator warranty.

J&M makes no other warranty, expressed or implied, and makes no warranty of merchantability or fitness for any particular purpose.

No employee or representative is authorized to change this warranty unless such change is made in writing and signed by an officer of J&M.



**MODEL 220
HYDRAULIC
IMPACT HAMMER**

TABLE OF CONTENTS

I.	<u>GENERAL INFORMATION</u>	<u>PAGE</u>
	A. General Description	I-1
	B. Major Components (line drawing)	I-1
	C. Specifications	I-5
II.	<u>PREPARATION FOR OPERATION</u>	
	A. General	II-1
	B. Safety Precautions	II-1
	C. Handling	II-4
	D. Connecting Crane Line To Hammer	II-5
	E. Attachment Of Lead Guides	II-6
	F. Attachment Of Drive Cap	II-6
	G. Mounting Hammer In Lead	II-7
	H. Connection Of Hydraulic Hoses	II-8
	I. Filling The Hammer Pressure Hose	II-9
	J. Filling Variable Stroke Cylinder Hoses	II-10
	K. Setting Variable Stroke Cylinder Pressure	II-10
	L. Fuel, Lubricating Oil And Grease	II-11
III.	<u>OPERATING INSTRUCTIONS</u>	
	A. Completion of Set-up and Maintenance	III-2
	B. Control Panel	III-2
	C. Starting And Warming Up The Engine	III-3
	D. Warming Hydraulic Oil	III-3
	E. Operation Of The Hammer	III-4
	1. Rated Hammer Energy	III-4
	2. Maximum blows per inch	III-4
	3. Stroke Control	III-4
	4. Stroke Setting	III-5
	F. Starting The Hammer	III-6
	G. Stopping The Hammer	III-6
	H. Single Blow Operation	III-6
	I. Emergency Stop	III-6
	J. Engine Shut Down	III-6
	K. Hot & Cold Weather Operation	III-7
IV.	<u>MAINTENANCE AND ADJUSTMENTS</u>	
	A. General	IV-1
	B. Maintenance - Daily	IV-2
	C. After Start-Up, Check The Following	IV-3
	D. Maintenance -Monthly	IV-3



**MODEL 220
HYDRAULIC
IMPACT HAMMER**

TABLE OF CONTENTS

IV.	<u>MAINTENANCE AND ADJUSTMENTS (CONTINUED)</u>	<u>PAGE</u>
	E. Maintenance - Every 4 Months	IV-3
	F. Annually	IV-3
	G. Severe Conditions	IV-4
	H. Lubrication	IV-4
	I. Hydraulic Oil	IV-5
	J. Capacities	IV-7
	K. Draining And Filling Hydraulic Reservoir	IV-7
	L. Changing The Hydraulic Return Filter Element	IV-8
	M. Setting Main Relief Valve	IV-9
	N. Setting Stroke Control (Clamp) Relief Valve	IV-10
	O. Tensioning Wire Ropes	IV-10
	P. Charging Accumulators	IV-12
	Q. Replacing Ram Connection	IV-13
	R. Bolt Torque Information	IV-14
	S. Checking & Replacing Recoil Dampener	IV-15
	T. Checking & Replacing Cushion Material	IV-15
V.	<u>HYDRAULIC CIRCUITRY</u>	
	A. Drive Pump	V-1
	B. Stroke Control Pump	V-2
	C. Other	V-3
	Hydraulic Schematic	V-4
	D. Hydraulic Components List	V-5
VI.	<u>ELECTRICAL CIRCUITRY</u>	
	A. Diesel Engine	VI-1
	B. Stroke Range Select	VI-2
	C. Hydraulic Hammer	VI-2
	D. Remote - Local Control	VI-2
	E. Engine Throttle	VI-3
	F. Tachometer	VI-3
	G. Other	VI-3
	Electrical Layout	VI-4
	Electrical Schematic	VI-5
	H. Electrical Components List	VI-6



**MODEL 220
HYDRAULIC
IMPACT HAMMER**

TABLE OF CONTENTS

VII. GENERAL DATA

- | | |
|----------------------------|-------|
| A. Abbreviations | VII-1 |
| B. Screws And Bolts | VII-2 |
| C. Serial Number Locations | VII-2 |

VIII. ORDERING PARTS

- | | |
|--|---------|
| A. Procedure | VIII-1 |
| B. Fitting Description Key | VIII-2 |
| Fitting Description Selector Chart - SC1 | VIII-3 |
| C. Hose Description Code | VIII-4 |
| D. Parts Identification | VIII-5 |
| E. Miscellaneous Accessories | VIII-48 |
| F. Recommended Spare Parts | VIII-51 |
| G. Recommended Tightening Torque | VIII-52 |



**MODEL 220
HYDRAULIC
IMPACT HAMMER**

I. GENERAL INFORMATION

A. GENERAL DESCRIPTION

The J&M Model 220 Hydraulic Hammer is a Free-Fall hammer. The ram is lifted by the hydraulic actuator and then allowed to free-fall, impacting the pile. The hammer has been designed to provide maximum flexibility by enabling the contractor to vary the energy range of the hammer to suit job conditions. The 220 hammer design incorporates an all hydraulic control system, with no electrical or electronic controls used, to ensure reliability and field serviceability. Further, without the need for vulnerable umbilical cords, this unit is readily adaptable to alternate hydraulic power sources.

The 220 hammer is normally powered by the same Model 175 power unit that powers J&M Vibratory Hammers and J&M Earth Augers. This permits the contractor to use a single power unit on jobs where both the Impact Hammer and a Vibratory Hammer or Auger are needed. The Hammer can also be powered by any source providing the required flow, pressure, cooling and filtration. The 220 Hydraulic Hammer delivers 46,000 ft-lbs (6359.7 Kg-M) of energy at its full stroke of 4'-0" (1.2M) at a blow rate of 40 blows per minute.

B. MAJOR COMPONENTS

The hammer system consists of 8 major components (Fig. 1) page I-4:

- Hydraulic Actuator
- Ram
- Guide Structure
- Lifting Bale
- Drive Cap
- Controls
- Interconnecting Hoses
- Power Unit

Hydraulic Actuator

The hammer is driven by the hydraulic actuator. The actuator is coupled to the ram using a shock absorbing, self aligning, connection. Hydraulic oil flows from the power unit, at pressure, to the actuator which accelerates the ram upward. Attached to the ram is a trip bar which activates a trip valve after the ram has risen a predetermined distance. Activation of the trip valve stops the flow of oil to the actuator. The ram then decelerates and free falls to impact the pile. Power unit energy is stored in a hydraulic accumulator while the ram is falling.



**MODEL 220
HYDRAULIC
IMPACT HAMMER**

I. GENERAL INFORMATION

B. MAJOR COMPONENTS (CONTINUED)

Ram

The ram is a one piece high strength steel forging. The one piece construction of the ram eliminates slack in the driving system and provides maximum energy transfer to the pile. The one piece construction also eliminates the dangers of structural failure known to exist in rams constructed of separate segments. High performance, non-metallic, bearings, retained within the ram, prevent guide column wear and reduces maintenance and lubrication requirements. The shock and vibration, generated when the ram impacts the pile, are isolated from the hydraulic actuator by an elastomeric, self aligning, coupling.

Guide Structure

The guide structure consists of tubular steel guide columns and connection plates. The guide columns serve to guide the ram and provide the rigidity required to allow the driving of batter piles. Guide columns, connecting plates and lifting bale are held together by tensioned wire ropes which run from the base plate to the top of the lifting bale. These cables provide a resilient means of connection and eliminate the need for keys or bolted connections. The hammer is designed to fit in 26" x 8" rail leads produced by J&M and other manufacturers. The connecting plates provide mounting points for the lead guide rails necessary for J&M leads and various other hammer guidance systems.

Lifting Bale

The lifting bale surrounds and protects the hydraulic actuator and hoses from damage and is the attachment point for the lifting sheave. Two energy storing hydraulic accumulators are mounted to, and protected by, the lifting bale. Incorporated in the lifting bale design are the connection flanges for the hydraulic supply hoses, and a shock absorbing hose support.

Drive Cap Assembly

Striking energy of the ram is transmitted to the pile through the three elements of the drive cap assembly. The ram impacts the forged steel striker block which self aligns and self centers within the lower connecting plate. Ram energy is transferred through cushion material into the DCB-X drive cap base. The DCB-X serves to retain the cushion material, Guide the piling, and adapt to various styles of J&M piling inserts. Piling inserts adapt the hammer to most popular types of piling and retain additional cushion material when required.



**MODEL 220
HYDRAULIC
IMPACT HAMMER**

I. GENERAL INFORMATION

B. MAJOR COMPONENTS (CONTINUED)

Controls

The hammer is controlled by a remote electric/hydraulic system in the power unit which allows for both manual single blow operation or automatic continuous stroke operation. The stroke of the ram can be varied between 12" (.3M) and 48" (1.2M), on-the-fly, allowing control of the hammer energy to suit various types of piling and soil conditions. Under continuous operation, the hammer will operate at 45 blows per minute at the maximum energy setting. The blow rate will increase at lower energy settings. Control of the continuous cycling of the hammer is fully hydraulic (non-electric), operated by valves contained within the actuator assembly. No maintenance or adjustment of these valves is normally required. The hammer can be operated from the control panel at the power unit, the remote pendant control or the radio remote control unit

Interconnecting Hoses

Hydraulic power is transmitted from the power unit to the hammer through 100 ft. (30M) of steel braid reinforced hydraulic hoses (4). High pressure, threaded type, quick disconnects on these hoses facilitate connection to the power unit without oil loss. Dust covers are provided to keep disconnects clean when the hammer is disconnected.

Power Unit

Power for the hammer is normally provided by a free-standing, Model 325, diesel-hydraulic power unit. The Model 325 is powered by a Caterpillar 3306 engine which develops 325 Hp at 2100 rpm. The totally enclosed power unit is mounted on a skid type fuel tank sub-base, and has lockable doors. Central lifting of the power unit is facilitated by an integral lifting bale. A control panel at the side of the unit contains all the operating gages and controls. A common reservoir supplies hydraulic oil to the main pump and the stroke control pump. Filtration and cooling means for the hydraulic oil are incorporated within the power unit. Electro/hydraulic valves are provided for hammer start/stop and stroke control. Pressure limiting valves are included for all systems. Four hydraulic hoses connect the power unit to the Model 220 hammer. This power unit can also be crane mounted for ease of operation.

If the crane is capable of providing the required flow, pressure, cooling and filtration to the hammer, it is possible to adapt it for hammer operation and eliminate the power unit



**MODEL 220
HYDRAULIC
IMPACT HAMMER**

- I. GENERAL INFORMATION
- B. MAJOR COMPONENTS (CONTINUED)

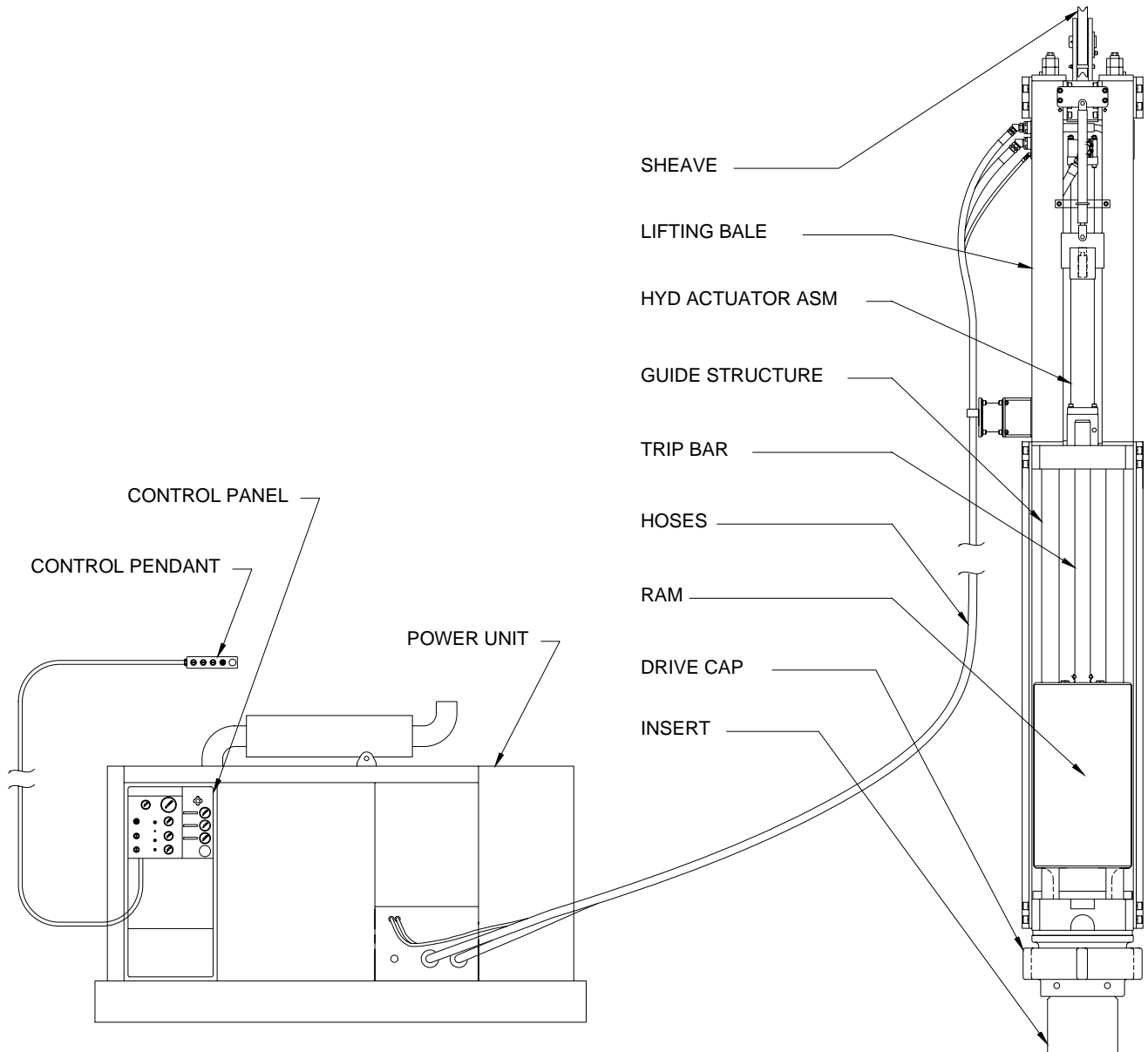



**MODEL 220
HYDRAULIC
IMPACT HAMMER**

I. GENERAL INFORMATION

C. SPECIFICATIONS

Working Specifications

Designation	J&M Model 220
Maximum stroke	4'-0" (1.2 Meter)
Rated energy @ maximum stroke	88,000 ft-lbs (119kj)
Blow rate @ maximum stroke	45 bpm
Minimum stroke	1' (0.3 Meter)
Rated energy @ minimum stroke	11,500 ft-lbs (15 kN-m)
Blow rate @ minimum stroke	75 bpm

Weights and Dimensions

Ram weight	22,000 lbs (5,215 kg)
Hammer weight (bare)*	35,000 lbs (8,573 kg)*
Complete operating weight with cap*, **	41395 lbs (18776 kg)**
Length (bare)**	121'-0" (6401mm)
Complete operating length with cap**	23'-7" (7188mm)**
Width (without guides)	32" (660 mm)
Depth	48" (1219mm)
Depth centerline to back	18" (457 mm)
Depth centerline to front	18" (457 mm)
Hydraulic hose length (standard)	150' (45 m)

*Weight includes one half of hydraulic hoses.

**Set up for 26" leads and 14" square concrete pile.

Power Unit

Designation	J&M Model 325
Engine	CAT 3306TA
Max. power	335 HP (250kW)
Operating speed	2100 rpm
Max. drive pressure	5,000 psi (345 bar)
Drive flow	87 gpm (330 lpm)
Stroke control pressure	4,300 psi (295 bar)
Stroke control flow	5.2 gpm (20 lpm)
Weight	9,600 lbs (4355 kg)*
Length	126" (320 cm)
Width	60" (152 cm)
Height	75.5" (192 cm)



**MODEL 220
HYDRAULIC
IMPACT HAMMER**

II. PREPARATION FOR OPERATION

A. GENERAL

When loading and unpacking the hydraulic hammer and accessories, use extreme care. For your protection, make a thorough inspection of the unit immediately on delivery. In case of any damage or shortage, notify the transit agent at once and have the delivering carrier make a notation on the freight bill. Use timber, heavy duty banding, etc to block ram movement during shipment.
(SEE SECTION II C FOR LIFTING INSTRUCTIONS)

B. SAFETY PRECAUTIONS

Safety is basically a matter of common sense. There are standard safety rules, but each situation has its own peculiarities which can not always be covered by rules. Therefore, your experience and common sense will be your best guide to safety. Be ever watchful for safety hazards and correct deficiencies promptly.

Use the following safety precautions as a general guide to safe operations:

1. Read the manual thoroughly before operating or working on the equipment.
2. Read and follow any safety instructions in the CATERPILLAR engine operators manual.
3. Only well trained and experienced personnel should attempt to operate or maintain this equipment.
4. Never adjust, lubricate or repair the unit when it is in operation, or lifted above ground level.
5. Never remove, paint over or cover warning or safety labels. If labels become damaged or unreadable, replace immediately.
6. All personnel should wear approved safety clothing, including **HARD HATS, SAFETY SHOES, SAFETY GLASSES** and **HEARING PROTECTION** when in the vicinity of this machinery.
7. Do not stand any closer to this equipment than necessary when it is in operation. Parts may loosen and fall. Piling may shatter or break. Never stand under operating, or elevated, equipment.
8. When maintaining or repairing the equipment, never substitute parts not supplied, or approved in writing, by J&M.
9. Do not weld, or flame cut, on this equipment.
10. Never use or store flammable liquids on or near the engine.
11. Insure that all lifting equipment, including cranes, wire rope, slings, hooks, shackles, etc., are properly sized for the worst case loads anticipated during operations.
12. If there are any questions about the weights, specifications, or performance of the unit, contact J&M before handling or operating the equipment.
13. If the equipment is to be used for anything other than driving plumb piles, contact J&M before using the unit.
14. Check wire rope clips for tightness, and check wire ropes for wear, daily.
15. Insure that ground vibrations will not damage or collapse adjacent structures or excavations.



**MODEL 220
HYDRAULIC
IMPACT HAMMER**

II. PREPARATION FOR OPERATION

B. SAFETY PRECAUTIONS (CONTINUED)

16. Remove all tools, parts and electrical cords before starting the unit.
17. When operating in an enclosed area, pipe exhaust fumes outside. Continued breathing of exhaust fumes may be fatal.
18. When servicing batteries, do not smoke or use open flames in the vicinity. Batteries generate explosive gas during charging. There must be proper ventilation when charging batteries.
19. When filling fuel tank, do not smoke or use open flame in the vicinity.
20. If abnormal equipment operation is observed, discontinue use immediately and correct the problem. Do not leave the equipment control pendant (radio control) unattended.
21. Store oily rags in approved containers, and away from engine exhaust system.
22. Make sure that the hammer is OFF before starting the power unit engine.
23. Do not adjust, or set, hydraulic pressures higher or lower than those specified in the manual.
24. Never operate this equipment with hydraulic hoses that are damaged or "kinked". Replace damaged hoses immediately.
25. Do not lift, or support, hydraulic hoses with wire rope slings.
26. Never attempt to connect quick disconnects when the power unit is running.
27. Do not pull on, or attempt to move equipment, with hydraulic hoses.
28. Do not attempt to locate hydraulic leaks with your hands. High pressure hydraulic leaks can penetrate the skin, causing severe damage, blood poisoning and infection. Do not attempt to repair leaks while the equipment is in operation.
29. Do not attempt to tighten, or loosen, fittings or hoses when the machine is in operation.
30. Power unit must always be placed on level, stable, ground.
31. Do not remove power unit heat shields, or operate power unit without heat shields. Severe fires may result.
32. A properly maintained fire extinguisher, suitable for oil fires, must be kept in the immediate vicinity of equipment operations.
33. When moving or transporting this equipment, insure that the vehicle or vessel is of sufficient capacity to handle the load, and that the equipment is properly tied down.
34. Always block the ram, to prevent movement during transport.
35. When moving or transporting this equipment, be sure that quick disconnect dust caps are tight, and that cap safety cables are in place. Be sure that all equipment parts are tight, or properly secured, before shipment. Unsecured parts may vibrate loose and fall, during transport, causing injury or property damage.
36. Keep crane boom, piles, leads, wire rope and other equipment at least 15' (5M) from electrical power lines, transformers and other electrical equipment, or at such distance as required by applicable safety codes.



**MODEL 220
HYDRAULIC
IMPACT HAMMER**

II. PREPARATION FOR OPERATION

B. SAFETY PRECAUTIONS (CONTINUED)

37. Rounded or damaged bolt heads or nuts should be replaced so that proper torque values may be obtained. Proper torque values are necessary to prevent parts on this equipment, leads and crane boom from loosening and falling. Refer to Torque Chart, in the manual, for proper values.
38. Always be sure that the crane line is aligned with the centerline of the pile. Do not side load crane boom or hammer. Dangerous crane boom, or hammer, damage may result.
39. Use tag line to control hammer whenever possible.
40. When driving "batter" piles, insure that the leads, and crane boom, have sufficient bending strength to handle the worst case load. Consult J&M.
41. Do not attempt to service hydraulic accumulators without first venting all high pressure gas from these units.
42. Pre-charge accumulators only to pressures specified, and only with Nitrogen gas.
43. Pile ends must be cut square, and flat, before cushion material and/or drive cap are placed onto pile.
44. Use only pile caps that are correctly sized for the type, cushion material and pile size being driven.
45. Before starting driving operations, check that the hammer, striker block and pile cap are properly aligned with the centerline of the pile. Dangerous lateral forces, generated by misalignment, may damage hammer or break piling, with resultant hazard from falling objects.
46. Stay well clear of ram point, pile cap and striker block. Fragments of metal may be broken, or spalled off, and ejected at high speed.
47. Large amounts of heat are generated, within cushion material, during driving. Cushion material, or flammable materials in the vicinity, may ignite. Personnel should use extreme caution, and avoid contact with ram point, cushion material and drive cap.
48. It is the responsibility of the contractor to determine what, if any, hazardous materials, or gases, may be emitted from cushion materials due to deterioration, decomposition, excessive temperature or combustion. Contact the cushion material manufacturer.
49. Frequently inspect and tighten the wire ropes, wire rope clips and pins that secure the drive cap to the hammer. Replace these components at the first sign of wear or fatigue. Tighten clips regularly.

REMEMBER, SAFETY IS EVERYONE'S BUSINESS.



**MODEL 220
HYDRAULIC
IMPACT HAMMER**

II. PREPARATION FOR OPERATION

C. HANDLING

Safe handling practices will insure protection of both the hammer and personnel working near the unit. Do not pick up the hammer by the guide columns. Doing so can scratch the surface finish on the columns and damage the ram bearings.

To lift hammer horizontally (See Fig 1):

The hammer is designed to be picked up by the lead guide rails. Use shackles at each of the four lifting holes provided in the lead guides to attach the four lifting cables. Alternately, the hammer can be picked up using the lifting sheave and a pin through the cable ears in the bottom plate. Ensure that the lifting cables are properly sized for the hammer weight and sling angle.

Always block the ram, to prevent movement during transport and / or lifting.

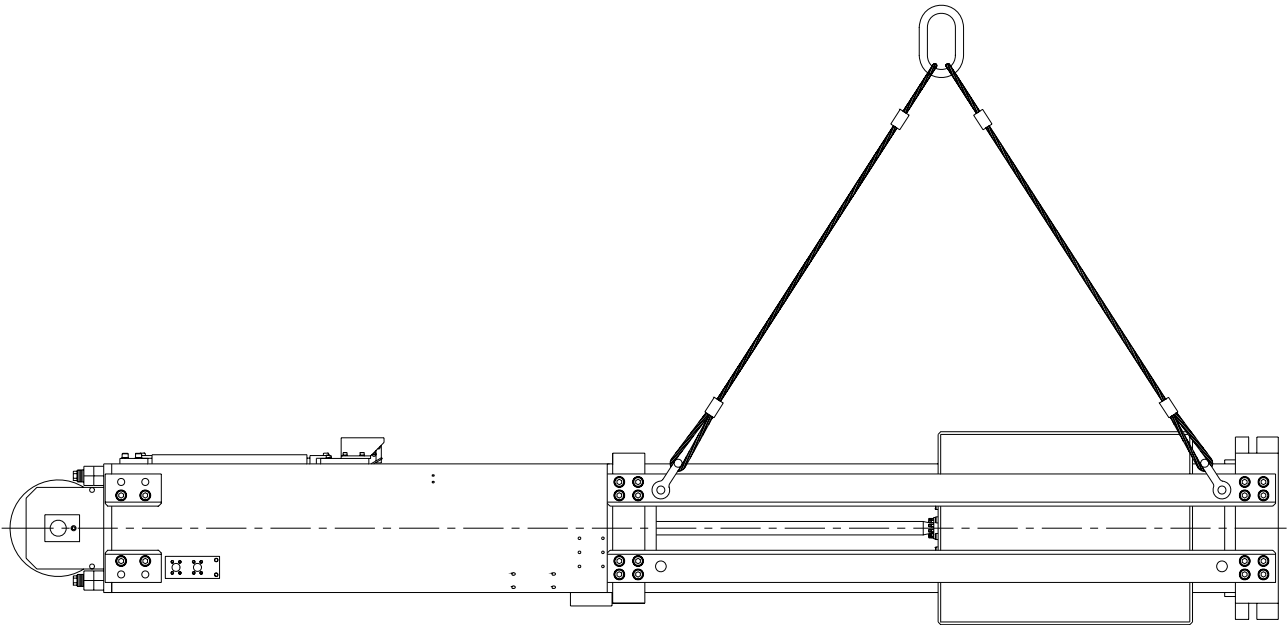

FIG 1



**MODEL 220
HYDRAULIC
IMPACT HAMMER**

II. PREPARATION FOR OPERATION

D. CONNECTING CRANE LINE TO HAMMER

Connect the crane line directly to the hammer using the lifting sheave. The hammer is designed to be used with a two-part line. If a single-part line is desired, the sheave can be replaced with a sleeve p/n 160777.

To lift the hammer to a vertical position, first remove the rope guide bolt and sleeve. (See Fig 2) Pass the crane wire rope around the lifting sheave and re-attach to crane boom. Lift hammer to the vertical position. Re-install rope guide bolt and sleeve.

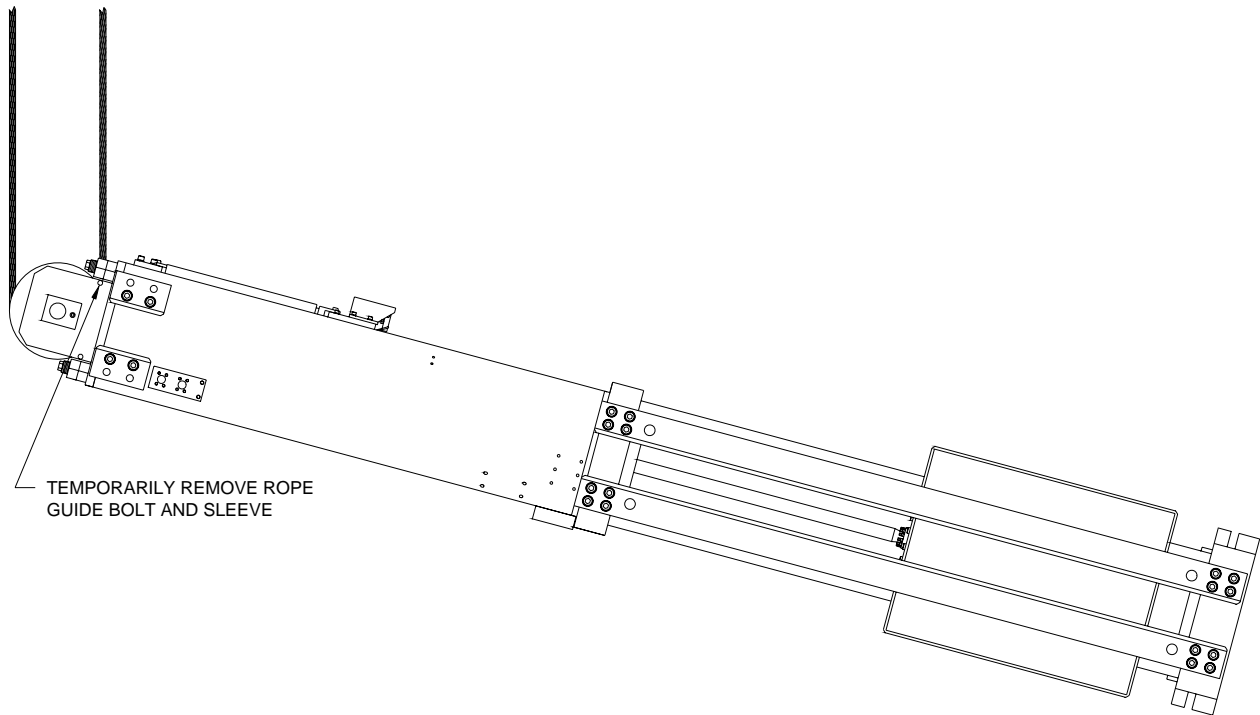

FIG 2



**MODEL 220
HYDRAULIC
IMPACT HAMMER**

II. PREPARATION FOR OPERATION

E. ATTACHMENT OF LEAD GUIDES

The hammer is usually shipped with lead or spud guides already in place. If they are not attached, bolt them into place at the sides of the hammer using the twenty bolt holes provided on each side of the hammer.

With fixed leads, it is sometimes convenient to stand the hammer in the leads prior to attachment of the back lead guides.

The lead guide attachment bolts should be properly torqued, using the lock washers provided, to prevent their coming loose. Torque 1.25-7UNC SHCS to 1,600 Ft-lbs (221.1 Kg-M).

Do not weld on hammer.

F. ATTACHMENT OF DRIVE CAP (See Fig. 3)

To attach drive cap: Set drive cap insert [11] on dunnage or firm ground. Set drive cap base [4] (DCB-2 for 32" leads) onto drive cap insert. Attach with wire rope through two holes provided.

Place 2"(50mm) thick and 22 1/2"(571mm) diameter cushion material [8] into top of DCB-1 drive cap base (2"(50mm) thick and 25"(635mm) diameter for DCB-2 drive cap base). Place 1/2"(13mm) thick aluminum plate [7] on top of cushion material. This plate holds the cushion material in place if it fractures during driving.

Place the 9 1/2" (243mm) thick tapered steel striker block [3] on top of the aluminum plate

Place the recoil dampener [9] around the top of the striker block.

Set the hammer onto the assembled drive cap set-up. The tapered striker block fits inside the bottom of the hammer and will lift the ram [1] as the hammer is lowered onto it. The hammer base plate [2] should sit squarely on the recoil dampener.

Attach the drive cap to the hammer with 3/4"(19mm) wire rope [10]. Insert bolt [6] through the holes in the cable ears on hammer base plate [2] to keep the 3/4"(19mm) wire rope [10] in place. Secure bolt [6] with the locking nut provided and fully tighten. Provide enough slack in the wire rope so that, when the hammer is lifted, 1"-2" (25-50mm) of space should exist between the bottom of the hammer and the recoil dampener.



**MODEL 220
HYDRAULIC
IMPACT HAMMER**

II. PREPARATION FOR OPERATION

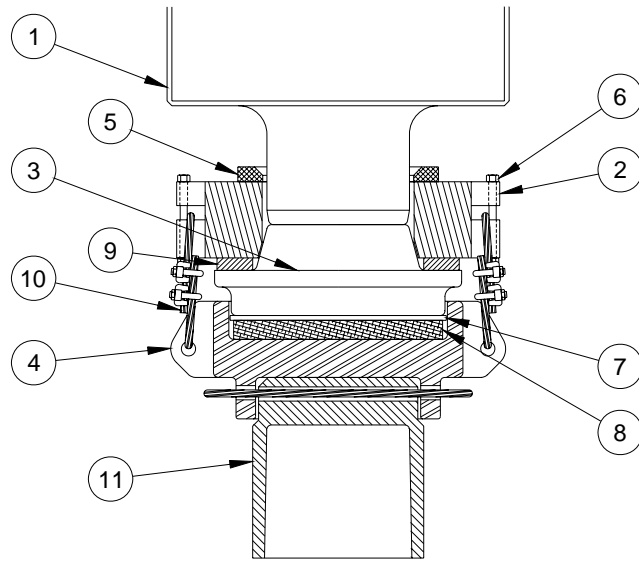

FIG 3

32" LEADS

1 Ram	SAME
2 Hammer Base Plate	SAME
3 Striker Block	SAME
4 Drive Cap Base	700006
5 Bumper	SAME
6 Bolt & Nut	SAME
7 Alluminum Plate	700004
8 Cushion	700002
9 Recoil Dampener	SAME
10 3/4" Wire Rope	
11 Drive Cap Insert	

G. MOUNTING HAMMER IN LEAD

To slide the hammer into swinging leads, in horizontal position, pick up hammer as described in Section II-C.

For vertical installation into leads, first attach the crane line to the hammer as described in Section II-D. and lift hammer carefully into vertical position. Position leads over the hammer and lift the hammer into the lead guide rails.

Alternately, remove the rear lead guide angles from the hammer. Position the hammer on the lead guide rails and re-install the rear guide angles. Be sure to torque the guide angle attachment bolts per Section II-E.



**MODEL 220
HYDRAULIC
IMPACT HAMMER**

II. PREPARATION FOR OPERATION

H. CONNECTION OF HYDRAULIC HOSES

Connection of hoses at the Power Unit

The hammer is connected to the power unit by four hydraulic hoses.
(See Fig. 4)

CAUTION: The power unit must be shut down during connection of the hydraulic hoses.

The hoses connect to the power unit with quick-disconnect couplings. The hose couplings are arranged so that the hoses can only be connected in the correct manner.

Clean the couplings with a lint-free cloth before making connections.

Make sure that the couplings are fully run up (tightened). They should be firmly hand tight. If wrenches are used, be careful not to over-tighten. Pipe wrenches are not recommended.

Connection of hoses at the Hammer

The Model 220 is normally shipped with the hoses attached to the hammer. If the hoses have been shipped separately, they must be connected to the hammer. Figure 4 shows the correct hose arrangement.

After the hoses have been connected, and tightened, to their respective fittings, they must be secured in the hose clamps on the hose bracket (See hammer assembly drawing in the PARTS LIST section). Be sure to leave enough slack in the hoses, above the hose clamps, to permit 3-4" (76-101mm) of downward movement by the hose clamp shock mounting elastomer.



MODEL 220 HYDRAULIC IMPACT HAMMER

II. PREPARATION FOR OPERATION

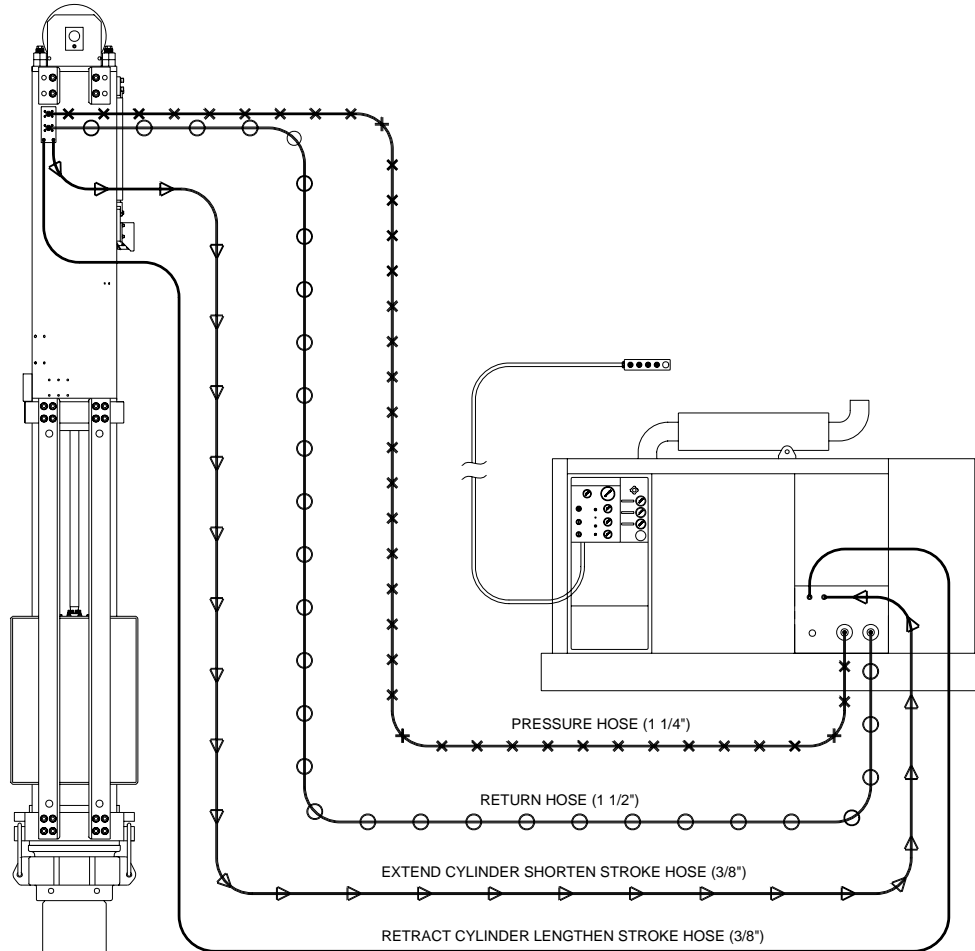

FIG 4

I. FILLING THE HAMMER PRESSURE HOSE

The hammer is normally shipped with the hammer hydraulic hoses full of oil and the unit may be used immediately. However, if the pressure hose has been removed from the hammer, the hose may need to be filled with hydraulic oil prior to full speed operation. It is not necessary to fill the return hose with oil.

Read SECTION III - OPERATING INSTRUCTIONS

Start and warm-up the engine in accordance with SECTION III C. With the engine warmed-up and running at 1500 rpm, turn and hold the hammer switch to the REVERSE position. The hoses will fill with oil in approximately two minutes. Do not engage any other switches on the control pendant during this two minute period.



**MODEL 220
HYDRAULIC
IMPACT HAMMER**

II. PREPARATION FOR OPERATION

J. BLEEDING THE VARIABLE STROKE CYLINDER LINES

The hammer is normally shipped with the two 3/8" hoses full of oil and the unit may be used immediately. However, if the hoses have been removed from the hammer, the hoses may need to be filled with hydraulic oil prior to driving operations.

Remove the hose from its fitting at the cylinder (P/N 160817) retract end. Place and hold the end of the hose in an adequate container or bucket.

Read SECTION III - OPERATION INSTRUCTIONS

Start and warm-up the engine in accordance with SECTION III C. With the engine warmed-up and running at 1000 rpm, turn the clamp switch, on the control pendant, to the CLOSE position. Oil should start flowing from the hose within 20 seconds. When the flow of oil is bubble free, return the clamp switch to the OFF position, and stop the diesel engine.

Reconnect and tighten the hose to the cylinder.

Remove the hose from its fitting at the cylinder extend end. Place and hold the end of the hose in an adequate container or bucket.

Start and warm-up the engine in accordance with SECTION III C. With the engine warmed-up and running at 1000 rpm, turn the clamp switch, on the control pendant, to the OPEN position. Oil should start flowing from the hose within 20 seconds. When the flow of oil is bubble free, return the clamp switch to the OFF position, and stop the diesel engine.

Reconnect and tighten the hose to the cylinder.

K. VARIABLE STROKE CYLINDER PRESSURE

The variable stroke cylinder pressure should be approximately 1500 PSI (103 Bar). If the J&M Model 325 power unit is always used with the Model 220 hydraulic impact hammer, the variable stroke cylinder pressure should already be properly set. Whenever a new job is started, or when the 325 power unit has been used to drive a vibratory driver/extractor, or when an alternate power unit is to be used, the variable stroke cylinder pressure should always be checked before starting driving operations.

Read SECTION III - OPERATING INSTRUCTIONS.



**MODEL 220
HYDRAULIC
IMPACT HAMMER**



**MODEL 220
HYDRAULIC
IMPACT HAMMER**

II. PREPARATION FOR OPERATION

K. VARIABLE STROKE CYLINDER PRESSURE (CONTINUED)

Disconnect the variable stroke cylinder lines (3/8" ID hoses) at the power unit quick disconnects. Start and warm-up the engine in accordance with SECTION III C. With the engine warmed-up and running at 1000 RPM, turn the clamp switch, on the control pendant, to the OPEN position. Observe the pressure on the clamp gage at the control panel. If the pressure is not 1500 PSI (103 Bar), the clamp relief valve will have to be re-adjusted to 1500 PSI (103 Bar) using the procedure in Section IV-N of the maintenance and adjustments chapter.

NOTE: DO NOT SET THE VARIABLE STROKE CYLINDER PRESSURE BY ADJUSTING THE CLAMP PRESSURE SWITCH. The clamp light [q] on the pendant should NOT come ON.

L. FUEL, LUBRICATING OIL AND GREASE

The following are reminders for lubrication maintenance procedures that should be performed in preparation for operation of the Model 220 hydraulic impact hammer. See the Caterpillar engine manual and the MAINTENANCE AND ADJUSTMENTS section of this manual for a description of these procedures.

1. Power Unit

- a. Check engine oil level
- b. Check hydraulic oil level
- c. Check for adequate fuel supply
- d. Check engine coolant level

2. Hammer

- a. Grease Columns
- b. Grease sheave
- c. Oil trip valve lever pivot



**MODEL 220
HYDRAULIC
IMPACT HAMMER**

**III. OPERATING INSTRUCTIONS
CONTROL PANEL WITH REMOTE CONTROL-PENDANT**

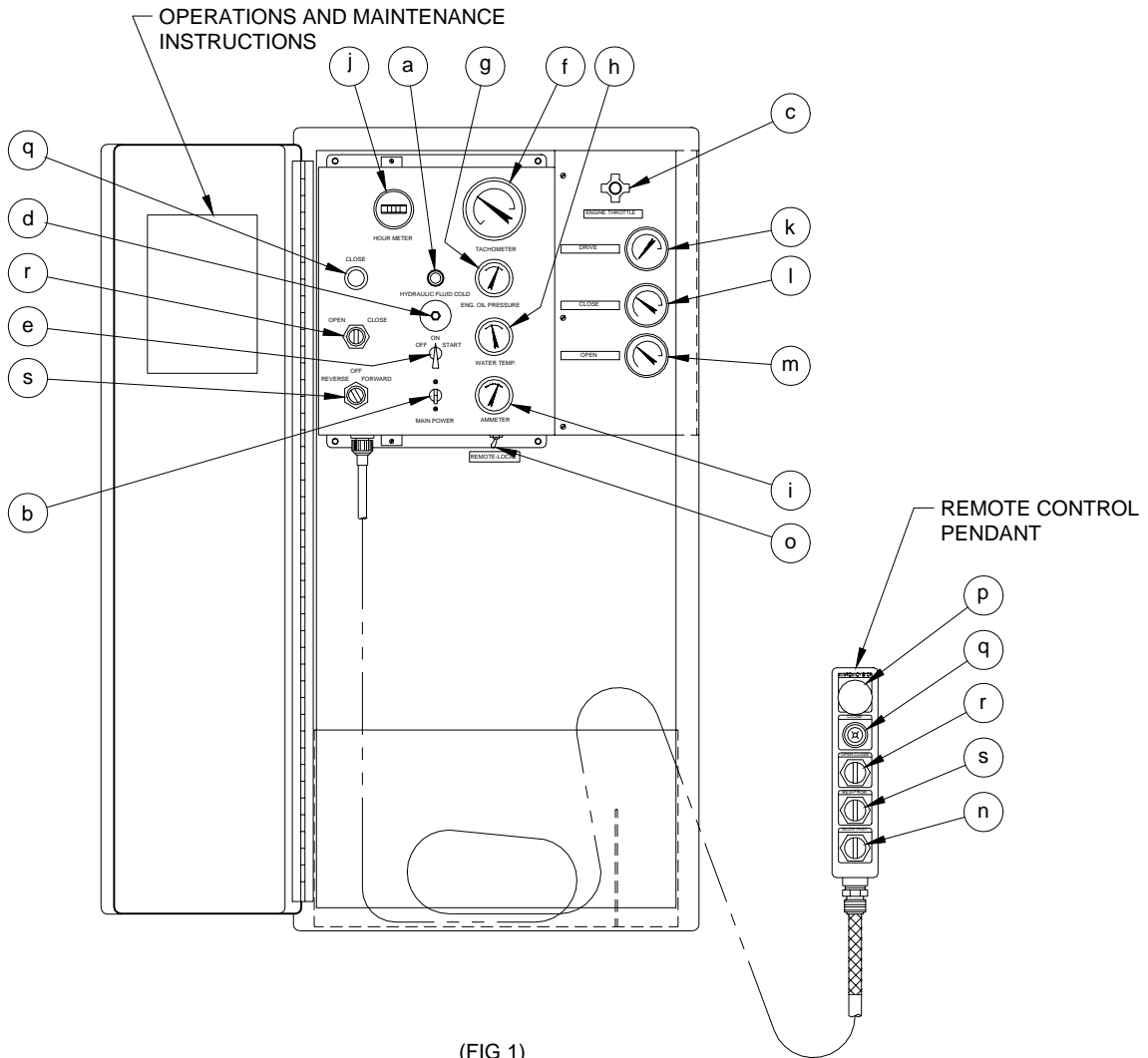

(FIG 1)



**MODEL 220
HYDRAULIC
IMPACT HAMMER**

A. COMPLETION OF SET-UP AND MAINTENANCE

1. Complete all preparation as described in Section II.
2. Read Section IV - MAINTENANCE AND ADJUSTMENTS and perform any required maintenance.
3. Read the Caterpillar engine manual and perform any required maintenance.

B. CONTROL PANEL

1. The control box, (Fig. 1, page III-1) at the side of the power pack, contains the controls and gages for the diesel engine and the hydraulic impact hammer. OPERATION AND MAINTENANCE INSTRUCTIONS are posted inside the door. The remote pendant, which duplicates the controls on the operating panel, is connected to the bottom of the panel and stored in the box below it.
2. Control panel contains the following controls and gages:
 - a. Hydraulic fluid cold light - comes on if hydraulic oil is below 60°F (16°C).
 - b. Main power switch (Circuit Breaker) - on/off switch for 24 volt electrical power. Must be "ON" for hammer operations.
 - c. Engine throttle.
 - d. Engine shut-down reset button - Must be held in, when starting engine, until oil pressure exceeds 30 PSI (2 Bar).
 - e. Engine "ON/OFF/START" switch - for diesel engine.
 - f. Engine tachometer.
 - g. Engine oil pressure gage.
 - h. Engine water temperature gage.
 - i. Engine ammeter.
 - j. Engine hourmeter.
 - k. Pressure gage - (Drive - Forward/Reverse).
 - l. Pressure gage - (Clamp Close) - Short stroke pilot pressure.
 - m. Pressure gage - (Clamp Open).
 - n. Engine throttle (Remote electric).
 - o. Remote-Local switch.
 - p. Emergency Stop Button - Push to stop engine.
 - q. Clamp light.
 - r. Clamp switch - Variable stroke.
 - s. Hammer Drive/Stop.
3. The OPERATION AND MAINTENANCE INSTRUCTIONS on the control panel are there as reminders only. They are not complete and therefore not intended to substitute for a thorough understanding of this Operating Manual.



**MODEL 220
HYDRAULIC
IMPACT HAMMER**

III. OPERATING INSTRUCTIONS

C. STARTING AND WARMING UP THE ENGINE

Before starting the engine, read the Caterpillar operation guide carefully. Follow the engine starting, operation and maintenance procedures in that manual.

The diesel engine should not be started if the temperature of the hydraulic oil is below 0°F (-18°C). The temperature may be read at the gage on the hydraulic reservoir. If ambient temperatures below 0°F (-18°C) are anticipated, an immersion heater for the hydraulic oil is available. Consult J&M for details.

The MAIN SWITCH on the control panel should be ON. Turn the hammer drive FORWARD/REVERSE switch on the control panel to OFF.

NOTE: Engine will not start unless the hammer switch is in the OFF position.

Pull out the ENGINE THROTTLE about half way.

Hold the shutdown reset button in and turn the ENGINE START SWITCH to START position. Hold the reset button in until the oil pressure reaches 30 psi 2 Bar. If the engine fails to start after 30 seconds of cranking, allow the starter to cool for two minutes before repeating the starting procedure.

As the engine starts, release the ENGINE START SWITCH. It will return to the RUN position.

Adjust the throttle until the engine is running at 1500 rpm and allow the engine to warm-up for five minutes.

Allow the temperature of the hydraulic oil to come up to at least 30°F (17°C) before starting the hammer.

D. WARMING HYDRAULIC OIL

The hydraulic hammer should not be operated at full pressure if the temperature of the hydraulic oil is below 60°F (16°C). The HYDRAULIC FLUID COLD light on the control panel will be lit if the oil temperature is below 60°F (16°C). Also, check the temperature gage on the reservoir.

If the temperature of the hydraulic oil is below 60°F (16°C), set the diesel engine at 2310 RPM and run the hammer until the temperature of the hydraulic oil exceeds 60°F (16°C). The HYDRAULIC FLUID COLD light will then go out. The engine rpm may now be set to the desired setting.

CAUTION: Do not operate the hammer if the hydraulic oil temperature exceeds 160°F (71°C) as this may damage hydraulic components.



**MODEL 220
HYDRAULIC
IMPACT HAMMER**

III. OPERATING INSTRUCTIONS

E. OPERATION OF THE HAMMER

The Model 220 hydraulic hammer is a free-fall type hammer. The ram is lifted by the hydraulic cylinder and then allowed to free-fall.

1. Rated Hammer Energy

Rated hammer energy of 88,000 ft-lbs (119 kJ) is achieved at an operating stroke of 4'-0" (1.2 m). Minimum operating energy of 11,500 ft-lbs (15 kN-m) occurs at an operating stroke of 1' (.3 m). The energy at which the hammer is operating may be determined by measuring the operating stroke, in feet (m), and multiplying the stroke by the weight of the ram 22000 lbs (9978 kg) to get energy in ft-lbs (kN-m). Stroke length may be measured by observing the stroke length scale (decal) located on the guide angles, and comparing them to the pointer on the ram. The stroke length scale is marked in 1/4 ft (.076m) increments.

2. Maximum blows per inch

Driving in excess of 10 blows per inch (25.4mm) is considered practical refusal. Driving in excess of 10 blow per inch is considered improper use and will void the hammer warranty.

3. Stroke Control

Stroke of the Model 220 hammer is controlled hydraulically via the location of the trip valve lever. The hammer may be operated at infinitely variable stroke length within the 4'-0" (1.2 m) to 1' (.3m) limits. The full stroke setting is the normal operating mode for the hammer. The reduced stroke setting is engaged via the control panel.



**MODEL 220
HYDRAULIC
IMPACT HAMMER**

III. OPERATING INSTRUCTIONS

E. OPERATION OF THE HAMMER (CONTINUED)

4. Stroke Setting

Stroke setting is controlled by the CLAMP OPEN-CLOSE switch. The full stroke mode is the normal hammer mode. The hammer will run in at any stroke length as long as the clamp switch remains in the middle, neutral position. To reduce stroke setting, turn the clamp switch to the OPEN position briefly. This will extend the variable stroke cylinder shortening the stroke. When stroke is at the length required, release the clamp switch. The switch will spring return to its neutral position. To lengthen the stroke turn the clamp switch to the CLOSE position briefly. This will retract the variable stroke cylinder lengthening the stroke. When stroke is at the length required, return the clamp switch to its neutral position. The stroke length may be changed while hammer is in operation.

The operation of the hydraulic hammer can be controlled directly from the control panel, by the remote-control pendant or with the radio control unit. These control locations have identical switches for hammer stop/start, engine RPM and stroke setting.

The hammer is controlled by three, two-way switches. These switches are labeled CLAMP OPEN-CLOSE, FORWARD-REVERSE and FAST/SLOW. The switches are labeled in this manner because Model 175 also operates J&M Earth Augers and Vibratory Hammer.



**MODEL 220
HYDRAULIC
IMPACT HAMMER**

III. OPERATING INSTRUCTIONS

F. STARTING THE HAMMER

After choosing the desired stroke setting, the hammer is started by turning the FORWARD-REVERSE switch to the FORWARD position. The hammer will continue to run as long as the switch is in the FORWARD position.

G. STOPPING THE HAMMER

The hammer is stopped by turning the FORWARD-REVERSE switch from the FORWARD position to the neutral position. The hammer may be stopped at any point in its cycle.

H. SINGLE BLOW OPERATION

The hammer can be made to deliver a single blow or a short series of blows using the FORWARD-REVERSE switch. To deliver a single blow, start the hammer as described above and as the ram begins to descend, turn the FORWARD-REVERSE switch back to the neutral position. The ram will fall, delivering a single blow. The hammer may be stopped after delivering any number of blows.

I. EMERGENCY STOP

When the diesel engine is running, pressing the EMERGENCY STOP button on the pendant, energizes the coil on the SHUTDOWN RESET. The Shutdown Reset opens and the engine and the hammer are stopped.

J. ENGINE SHUT DOWN

Stop the hammer. Allow the diesel engine to run for 5 minutes at 1500 RPM. Reduce engine rpm to 1000 RPM for 30 seconds. Stop the engine by turning the ENGINE START switch to OFF. The MAIN SWITCH on the control panel should be OFF.



**MODEL 220
HYDRAULIC
IMPACT HAMMER**

III. OPERATING INSTRUCTIONS

K. HOT & COLD WEATHER OPERATION

Field experience has shown that certain modifications to normal operating procedures can improve hammer performance in hot or cold weather. Use the following procedures in hot weather:

1. DO NOT set engine RPM any higher than is necessary to achieve useful penetration or stroke length. Excessive RPM (oil flow) generates heat.
2. Observe the Drive Pressure Gage while the hammer is operating. The pressure should approach the relief valve setting only momentarily when the ram impacts the pile. If the pressure is observed to remain at, or near, the relief valve setting for a prolonged portion of the operating cycle, reduce engine RPM.
3. When operating at short stroke, reduce engine RPM as far as possible.
4. Be sure that the engine water/anti-freeze ratio is in the recommended range. insufficient or excessive anti-freeze will reduce the cooling capacity of the radiator.
5. Check coolant level regularly and keep full.
6. Be sure that the power unit main relief valve is set at the maximum allowable setting. See Section IV-M.
7. Check the engine radiator and oil cooler often and carefully for dirt, dust or debris. Blow out cooler and radiator with air or a pressure washer whenever a build up is observed to maintain maximum cooling efficiency.
8. Be sure that adjacent structures or equipment are not obstructing air flow into or out of the power unit.



**MODEL 220
HYDRAULIC
IMPACT HAMMER**

III. OPERATING INSTRUCTIONS

K. HOT & COLD WEATHER OPERATION (CONTINUED)

Use the following procedures in cold weather: Below freezing weather calls for particular care so that the hammer is gradually brought up to operating temperature before submitting it to the shock loading of full driving force.

1. Be sure that the engine water/anti-freeze ratio is in the recommended range.
2. Always warm up the engine before applying any load.
3. In very cold weather (below 20°F / -7°C) the use of a reservoir heater is recommended. The J&M 325 Power Unit is equipped with a "heater well" to facilitate installation of an electric heater.
4. In extremely cold, arctic, conditions (below 0°F / -18°C) it may be necessary to use a special, Arctic type, hydraulic oil. Consult J&M or your hydraulic oil supplier for recommendations.
5. Consult the Caterpillar engine manual for appropriate, cold weather, engine lubricant.
6. After the engine is warmed up, set engine speed to 1500 RPM. Turn the FORWARD/REVERSE switch to REVERSE for 5 minutes. This will circulate warmer hydraulic oil through, and warm, the Hydraulic Actuator.
7. With the engine running at 1500 RPM, operate the hammer in the short stroke mode for approximately 3 minutes
8. The hammer may now be operated in the long stroke mode at 1500 engine RPM.
9. DO NOT operate the engine above 1500 RPM until the hydraulic oil temperature reaches 60°F (16°C)
10. In extreme cold climates, where 24 hour / day engine running is appropriate, contact I C E for special "Arctic Circuit" information.



**MODEL 220
HYDRAULIC
IMPACT HAMMER**

IV. MAINTENANCE AND ADJUSTMENTS

A. GENERAL

Preventive maintenance includes normal servicing that will keep the hydraulic hammer in peak operating condition and prevent unnecessary trouble from developing. This servicing consists of periodic lubrication and inspection of the moving parts and accessories of the unit. J&M equipment is engineered to provide reliable operation and a long service life under normal operating conditions. Equipment reliability and service life can be improved by following the maintenance procedures in this manual.

Lubrication is an essential part of preventative maintenance, controlling to a great extent the useful life of the hammer. Different lubricants are needed and some components require more frequent lubrication than others. Therefore, it is necessary that the instructions regarding types of lubricants and frequency of their application be closely followed.

To prevent minor irregularities from developing into serious conditions that might involve shut-down and major repair, several other services or inspections are recommended for the same intervals as the periodic lubrications. The purpose of these services or inspections is to assure the uninterrupted operation of the hammer. Thoroughly clean all lubrication fittings and caps and their surrounding surfaces before servicing. Prevent dirt from entering with lubricants and fuel.

The intervals given in the schedule are based on normal operation. Perform these services, inspections, etc. more often as needed for operation under abnormal or severe conditions.



**MODEL 220
HYDRAULIC
IMPACT HAMMER**

IV. MAINTENANCE AND ADJUSTMENTS

B. MAINTENANCE - DAILY

PRIOR TO STARTING THE POWER UNIT AT EACH SHIFT CHECK THE FOLLOWING ITEMS.

Check wire rope on drive cap for wear, and rope clamps for tightness.

Check for proper slack in wire rope holding drive cap. Adjust for 1"-2" (25mm-51mm) of space between hammer and recoil DAMPENER

Check for loose bolts, nuts, tie-wires or other components. Re-torque bolts and nuts on new hammer after 4 hours.

Check recoil dampener for damage. Dampener should not be less than 1-1/4" (32mm) thick with hammer weight on dampener(See Section II-F).

Check for adequate cushion material (See Section II-F).

Check Engine oil level.

Check engine water level.

Lubricate trip valve lever at pivot and wheel on valve.

Lubricate hammer guide columns.

Torque 16 ram / cylinder rod connection bolts.

Check the oil level in the hydraulic reservoir and refill if necessary.

CAUTION: It is absolutely imperative that no dirt or other impurities be permitted to contaminate the hydraulic oil. Any contamination will drastically shorten the life of the hydraulic system.

Visually check all hoses for signs of damage or cuts that might cause hose failure during operation. Be sure all connections are tight, especially the quick-disconnect couplers.

Electrical components need no maintenance except periodic wiping with a clean, dry, lint-free cloth to remove dust.

Perform all daily maintenance checks and lubrication indicated in the caterpillar operation guide.



**MODEL 220
HYDRAULIC
IMPACT HAMMER**

IV. MAINTENANCE AND ADJUSTMENTS

C. AFTER START-UP, CHECK THE FOLLOWING

Check all hydraulic hoses for leaks. Make sure they hang freely with no kinks.

Check both pumps and all hydraulic manifolds for leaks.

Check the filter indicator. The return filter on the power unit must be checked with the diesel engine running at maximum RPM and oil temperature at or above 60°F (16°C).

D. MAINTENANCE -MONTHLY

Re-Torque ALL hammer bolts per Torque Table Page VIII-52???.

Retorque set screws on cylinder rod super nut.

Inspect ram bumpers at top of stroke.

E. MAINTENANCE - EVERY 4 MONTHS

Have the hydraulic oil tested by a local hydraulic service center. Replace if required.

Disassemble, inspect and lubricate the connection between cylinder rod and the ram.

Check the nitrogen gas charge in both accumulators.

F. ANNUALLY

Remove, inspect, lubricate and re-tension the four wire rope assemblies that hold the hammer together. (Tensioning tool required)

Replace 8 Ram Bearings (P/N 160447).



**MODEL 220
HYDRAULIC
IMPACT HAMMER**

IV. MAINTENANCE AND ADJUSTMENTS

G. SEVERE CONDITIONS

The servicing intervals specified are based on normal operation conditions. Operation under unusual conditions require some adjustments in servicing intervals.

When the average temperature is above 89°F (31°C) or below 10°F (-12°C), reduce servicing intervals to one half of those specified above.

When operating in the presence of dust or sand reduce servicing intervals to one-third of those specified.

When operating in air with a high salt or moisture, the servicing intervals need not usually be changed. However, the unit should be inspected weekly to determine if additional servicing might be required. Have hydraulic oil tested every 2 months.

During stand-by or inactive periods, the servicing interval may be twice those specified. The unit should be exercised every 30 days or less, depending on conditions.

H. LUBRICATION

Diesel Engine (Crankcase)

Follow the engine manufacturer's maintenance schedule and the lubricating oil specifications outlined in the CATERPILLAR OPERATION GUIDE.

The lubricant shall meet the performance requirements of API Service Classification "CD" or MIL-L-2104C.

For operation in extreme sub-zero climate, refer to the CATERPILLAR OPERATION GUIDE, Crankcase Lubricating Oils, or contact the nearest Caterpillar representative. (CAT bulletin #SEBU5898-06)

New units are shipped with ASHLAND 400M + HDT, 15W40, but the following multi-grade crankcase oils are recommended for use or replacement in normal operation (10°F to 90°F) (-12°C to 32°C).



**MODEL 220
HYDRAULIC
IMPACT HAMMER**

IV. MAINTENANCE AND ADJUSTMENTS

H. LUBRICATION (CONTINUED)

AMOCO	15W-40	300
ARCO	15W-40	Fleet S3 Plus
BORON (BP)	15W-40	Vanellus C Extra
CHEVRON	15W-40	Delo 400
CITGO	15W-40	C500 Plus
CONOCO	15W-40	Fleet Supreme
EXXON	15W-40	XD3
GULF	15W-40	Super Duty Plus
MOBIL	15W-40	Delvac Super
PHILLIPS	15W-40	Super HD II
SHELL	15W-40	Rotella T
SUN	15W-40	Sunfleet Super C
TEXACO	15W-40	URSA Super 3
UNION	15W-40	Guardol
VALVOLINE	15W-40	All Fleet

I. HYDRAULIC OIL

Hydraulic System

To maintain the maximum operating efficiency in the precision parts of the hydraulic system, it is extremely important to eliminate factors which can cause breakdowns or unsatisfactory performance in the system. Among the most common of these factors are rust, corrosion, contamination and products of oil deterioration. Most problems can be minimized or avoided simply by maintaining a disciplined preventive maintenance program.

Some simple steps to follow as part of that program are:

- a. Keep stored oil dry and clean at all times and always store in clean containers.
- b. Always clean tools, spouts, lids, funnels, etc. when used in conjunction with the transfer of oil.
- c. Never put dirty oil into the hydraulic system. Use only clean, uncontaminated oil of the types recommended below. Never return to the system any oil which has leaked out.

CAUTION: When replacing or adding oil, be extremely careful to keep foreign material from entering the system. Foreign material in the hydraulic system can drastically effect the life and operation of many hydraulic component parts.



**MODEL 220
HYDRAULIC
IMPACT HAMMER**

IV. MAINTENANCE AND ADJUSTMENTS

I. HYDRAULIC OIL (CONTINUED)

- d. Clean or replace filter elements at the first indication that they are dirty or ineffective.
- e. Have hydraulic oil tested by the local supplier on a regular basis. Laboratory oil analysis can detect contamination, products of hydraulic component wear, water, oxidation or loss of viscosity long before it is visible to the eye and before significant component damage has occurred.
- f. Prevent water from entering the hydraulic system. Even minute amounts of water in the hydraulic oil will accelerate oil deterioration and oxidation.
- g. DO NOT operate the unit if oil temperature exceeds 160°F (71°C). Excessive hydraulic oil temperature will accelerate oil deterioration and oxidation.

Mixing of different manufacturers' hydraulic oil is not recommended. However, it can be done if the oils are miscible (contain the same base and additive). It may be necessary to contact an oil supplier to determine this.

New power units are shipped with CHEVRON Clarity AW46 hydraulic oil. This oil exceeds the requirements of both the E.P.A. and U.S. Fish and Wildlife Service for non-toxicity and is inherently biodegradable. **ADDING ANY OTHER OIL FROM THE LIST BELOW, WILL CONTAMINATE THE CLARITY OIL AND THE SYSTEM WILL NO LONGER BE ENVIRONMENTALLY FRIENDLY.**

Should the customer choose to use an alternate oil, the following recommendations may be used when replacing oil in the hydraulic system.

FIRST Preference Group:

CHEVRON	Clarity AW46
MOBIL	DTE-15
SUN	2105

SECOND Preference Group:

ARCO	Duro AW46
CHEVRON	Hydraulic AW46
PHILLIPS	Magnus A46
SHELL	Tellus 46



**MODEL 220
HYDRAULIC
IMPACT HAMMER**

IV. MAINTENANCE AND ADJUSTMENTS

I. HYDRAULIC OIL (CONTINUED)

THIRD Preference Group:

BORON	Energol HLP46
CITGO	A.W. Hydraulic 46
CONOCO	Super 46
EXXON	Nuto H46
GULF	Harmony 46AW
SUN	Sunvis 846
TEXACO	Rando HD AZ46
UNION	Unax AW46

Whenever oils from the second preference group are used, it is necessary to test the oil more often to insure that viscosity remains within recommended limits while in service. Using oils from the third preference group requires even a more discerning inspection than use of oils from the second group.

The recommended oils were chosen based on the hydraulic system operating temperature range being 5°F (-15°C) (cold ambient start-up) to 160°F (71°C) (maximum operating).

When operating in arctic conditions, it is recommended to use an immersion heater to pre-heat the oil prior to starting. Contact J&M for other arctic operating procedures. It may also be necessary in extremely cold or hot climates to use a different viscosity oil which is better adapted to adverse conditions. Contact the nearest oil supply representative for suggested procedures.

CHEVRON Clarity AW46 hydraulic oil is available from J&M in five gallon cans. See SECTION VIII - ORDERING PARTS, page VIII-48.

J. CAPACITIES

1. Diesel Engine Crankcase	21	Quarts
2. Hydraulic System (Reservoir)	275	Gallons
3. Fuel Tank Sub-Base (Diesel)	130	Gallons
4. Engine Cooling System	40	Quarts

K. DRAINING AND FILLING HYDRAULIC OIL RESERVOIR

1. The Hydraulic reservoir is drained by removing a plug on the bottom of the reservoir.
2. The hydraulic reservoir is filled by the manual pump mounted on the back (engine side) of the reservoir. All oil is pumped into the reservoir through the return filter (F2) to insure no dirt enters the hydraulic system.



**MODEL 220
HYDRAULIC
IMPACT HAMMER**

IV. MAINTENANCE AND ADJUSTMENTS

L. CHANGING HYDRAULIC RETURN FILTER ELEMENTS

1. The return filters are located on the hydraulic reservoir above the hex key rack.
2. To remove the return filter elements, you must use a filter wrench capable of accepting a 5" diameter filter. (Available at your local auto-parts store.) Unscrew the return filter elements counterclockwise to remove. Remove both filter elements and gaskets from the filter housing.
3. Clean filter housing with a lint free rag.
4. Install the new gaskets to the new filter elements. Apply a light coating of multi-purpose grease to the top of each gasket.
5. Screw the return filter elements and gaskets clockwise onto the filter housing until the gaskets make contact to the filter housing base.
6. Using the filter wrench, tighten both return filter elements approximately 3/4 of a turn.
7. Repeat above with the other two return filters.
8. With four new return filter elements installed, start the power unit and run for approximately three minutes. **CHECK FOR LEAKS.**



**MODEL 220
HYDRAULIC
IMPACT HAMMER**

IV. MAINTENANCE AND ADJUSTMENTS

M. SETTING MAIN RELIEF VALVE

1. Locate main relief valve (P/N 130503) on power unit directional control manifold. Manifold is located behind the large quick disconnects at the coupler panel. See page VIII-42 item 6.
2. While holding the valve adjusting screw with a hex key, loosen the adjusting screw jam nut with an open end wrench.
3. Make an initial adjustment of the screw by turning it approximately 1/8th turn in the desired direction. (Turning the screw clockwise will increase the pressure setting. Turning counter-clockwise will decrease pressure.)

CAUTION: NEVER ADJUST THE RELIEF VALVE WHILE THE SYSTEM IS UNDER PRESSURE.

4. Close all power unit doors.
5. Disconnect the pressure and return (largest) disconnects at the power unit.
6. Start and warm up diesel engine. When engine is warmed up, increase engine RPM to maximum.
7. While observing the DRIVE pressure gage, turn the FORWARD/REVERSE switch to FORWARD. The pressure should read 4500 PSI (310 Bar).
8. If the pressure is not correct, repeat steps 3 thru 8.
9. When the desired pressure is achieved, hold the adjusting screw with a hex key and tighten the adjusting screw jam nut.



**MODEL 220
HYDRAULIC
IMPACT HAMMER**

IV. MAINTENANCE AND ADJUSTMENTS

N. SETTING VARIABLE STROKE CONTROL (CLAMP) RELIEF VALVE

1. Locate stroke control relief valve (P/N 100898) on power unit clamp manifold. Manifold is located behind the small quick disconnects at the coupler panel. See page VIII-44 item 4.
2. While holding the valve adjusting screw with an open end, loosen the adjusting screw jam nut with an open end wrench.
3. Make an initial adjustment of the screw by turning it approximately 1/8th turn in the desired direction. (Turning the screw clockwise will increase the pressure setting. Turning counter-clockwise will decrease pressure.)

CAUTION: NEVER ADJUST THE RELIEF VALVE WHILE THE SYSTEM IS UNDER PRESSURE.

4. Close all power unit doors.
5. Disconnect the variable stroke control (smallest) disconnects at the power unit.
6. Start and warm up diesel engine. When engine is warmed up, increase engine RPM to maximum.
7. While observing the CLOSE pressure gage, turn the CLAMP switch to CLOSE. The pressure should read 1500 PSI (103 Bar).
8. If the pressure is not correct, repeat steps 3 thru 8.
9. When the desired pressure is achieved, hold the adjusting screw with an open end wrench and tighten the adjusting screw jam nut.
10. Do not reset the variable stroke control pressure by adjusting the "Clamp Pressure Switch".

O. TENSIONING WIRE ROPES

1. Clean dirt and excess paint from the threads on the wire rope assembly. Check that the centering nut and the lock nut can be fully threaded onto these threads by hand.
2. Install the wire rope assembly from the bottom plate of the hammer. If the rope gets stuck between the bottom plate and the top plate, it is often helpful to twist the rope while pushing the rope through. After the threaded end of the rope assembly exits the top plate, it will be necessary to hand guide the end of the rope through the lifting bale to the top rope mounting hole. **USE EXTREME CAUTION NOT TO DAMAGE THE THREADS.** Grease the threads.



**MODEL 220
HYDRAULIC
IMPACT HAMMER**

IV. MAINTENANCE AND ADJUSTMENTS

O. TENSIONING WIRE ROPES (CONTINUED)

3. When fully inserted, rotate the wire rope assembly until the anti-rotation roll pin on the wire rope lower fitting slides into the hole in the bottom plate.
4. Thread the centering nut onto the threaded wire rope fitting until it is fully hand tight. Be sure the machined extension on the nut fits into the hole in the lifting bale. Repeat steps 1 thru 4 to all four wire rope assemblies.
5. Install the 1.00-8UNC pulling stud (P/N 160781) into the female threaded hole in the wire rope assembly. Pulling stud must be screwed into the threaded hole as far as it will go.
6. Slide the cylinder support frame (P/N 160739) over the pulling stud and position on the lifting bale.
7. Slide tensioning cylinder (P/N 160783) onto pulling stud and secure with two nuts (P/N 400051). Tighten nuts to remove "slack" from the wire rope. When tightening this 1.00-8UNC nut, hold rope from turning with the flats on the threaded rope fitting.
8. Connect a hydraulic hand pump (P/N 160785), with gage, to the tensioning cylinder.
9. Operate hand pump, extending cylinder, until gage reads 8,500 PSI (586 Bar) (15 ton).
10. Tighten the centering nut onto the lifting bale by hand.
11. Retract the extending cylinder, re-tighten the 1" nuts, and repeat steps 9 - 11 until correct tension (step 9) is achieved.
12. Remove the tensioning cylinder, pulling stud and cylinder support frame.
13. While holding the centering nut, thread the locking nut onto the threaded rope fitting and fully tighten against the centering nut. Repeat steps 5-13 to all 4 wire rope assemblies.

THE TOOLS LISTED ABOVE ARE INCLUDED IN WIRE ROPE TENSIONING KIT (P/N 810713).



**MODEL 220
HYDRAULIC
IMPACT HAMMER**

IV. MAINTENANCE AND ADJUSTMENTS

P. CHARGING ACCUMULATORS

CAUTION: DO NOT CHARGE (FILL) ACCUMULATORS WITH ANY OTHER GAS THAN NITROGEN. DO NOT ATTEMPT TO DISASSEMBLE EITHER ACCUMULATOR WITHOUT REMOVING (VENT) THE ENTIRE GAS CHARGE.

1. Connect the charging kit (P/N 810833) to a 2000+ PSI (138 Bar) nitrogen gas bottle.
2. Unscrew the dirt cover from the accumulator gas valve.
3. Connect accumulator adapter assembly (charge kit) to the accumulator, gas valve, to be charged.
4. Screw in (CW) "T" screw, on accumulator adapter assembly to depress (open) the accumulator gas valve.
5. Read the existing accumulator charge pressure on the charge kit gage. See page V-4 for correct pressures.
6. To increase charge pressure, carefully "crack" open the nitrogen gas bottle valve until the charge kit gage pressure reaches the specified pressure level.

CAUTION: DO NOT OPEN NITROGEN VALVE RAPIDLY, AS GAS BOTTLE PRESSURE MAY EXCEED ACCUMULATOR PRESSURE RATING.

7. To decrease charge pressure, open the bleed valve, on the accumulator adapter, until the charge kit gage reaches the specified pressure level.
8. After the desired charge pressure has been attained, allow the system temperature to stabilize for 10 to 15 minutes, then recheck the charge pressure.
9. Unscrew the "T" screw, on accumulator adapter assembly to close the accumulator gas valve.
10. Remove charge kit and re-install the gas valve dirt cover.



**MODEL 220
HYDRAULIC
IMPACT HAMMER**

IV. MAINTENANCE AND ADJUSTMENTS

Q. REPLACING RAM CONNECTION

Lay hammer down on flat surface or dunnage, with the trip bar up.

Loosen the set screws, in the super nut (P/N 160465).

Remove 16 3/4" SHCS in the top plate (P/N 160923) holding the cylinder rod in the ram.

Push the cylinder rod into the actuator cylinder until the threaded end of the cylinder rod is well clear of the ram.

Remove the nylon insert (P/N 160929), the two elastomers (P/N 160921) the two back-up rings (P/N 160919) and the bottom plate (P/N 160925) from the ram cavity.

Remove the rod flange (P/N 160927), the super nut, the other nylon insert and the top plate (P/N 160923) from the cylinder rod.

Carefully clean and lubricate the threads on the cylinder rod, the super nut and the rod flange. All nuts should thread onto the cylinder rod by hand. Clean any grime or loose pieces from cavity.

Place the top plate and one of the nylon inserts on the cylinder rod without touching or marking threads.

Thread the super nut onto cylinder rod, with the hex heads up (toward the top plate), until the top of the nut is approximately 0.25 inches from the top end of the cylinder rod threads.

Thread the rod flange, with the flange end down, onto the cylinder rod until it contacts the super nut.

Torque super nut set screws to 233 Ft-Lbs (32.2Kg-M) (torque wrench required) in a circular pattern. Increase torque value in three equal steps. Re-check the final torque values at least three times to be sure it is not affected by adjacent screws.

Re-install bottom plate, the back-up rings, the elastomers, the other nylon insert and all of the insert spacers in the cavity of the ram.

Apply Hi-Molly grease to both sides of the rod flange.

Slide cylinder rod assembly in the ram cavity until the rod flange comes in contact with the nylon insert.

Position the other nylon insert on the insert spacers and then the top plate. Line up bolt holes, thread and torque all 16 SHCS.



**MODEL 220
HYDRAULIC
IMPACT HAMMER**

IV. MAINTENANCE AND ADJUSTMENTS

R. BOLT TORQUE INFORMATION

The only way to actually tighten high strength bolts is with a torque wrench. Proper use of the torque wrench is important. To obtain the listed torques, a steady pull should be exerted to the handle until the desired torque is reached.

The following torque specifications apply to the bolts from the component assemblies listed. Whenever any of these bolts, are replaced, the given torque specifications should be adhered to.

LIFTING BALE Page VIII-6

Item 72	5/8"-11	233 Ft-Lbs (32.2Kg-M)
Item 35	1"-8	1009 Ft-lbs (139.4Kg-M)

RAM ASSEMBLY Page VIII-8

Item 20	3/4"-10HHCS	275 Ft-Lbs (38Kg-M)
---------	-------------	---------------------

ACTUATOR MOUNTING Page VIII-9

Item 4	3/4"-10SHCS	417 Ft-Lbs (57.6Kg-M)
--------	-------------	-----------------------

ACTUATOR ASSEMBLY Page VIII-14 & 15

Item 7	1/2"-13	119 Ft-Lbs (16.4Kg-M)
Item 3, 30, 37	3/4"-10	417 Ft-Lbs (16.4Kg-M)
Item 14, 23, 34, 38	1"-8	1009 Ft-Lbs (139.4Kg-M)



**MODEL 220
HYDRAULIC
IMPACT HAMMER**



**MODEL 220
HYDRAULIC
IMPACT HAMMER**

IV. MAINTENANCE AND ADJUSTMENTS

S. CHECKING & REPLACING RECOIL DAMPENER

The thickness of a new recoil dampener with hammer weight on dampener is 1 1/2"(38mm). If the thickness is less than 1 1/4"(32mm), the dampener should be replaced.

To replace recoil dampener: Loosen wire rope holding drive cap to hammer. Pick up hammer to allow old dampener to be removed. Replace with new dampener. Re-tighten clamps on wire rope. Wire rope should be adjusted so that with hammer lifted 1-2"(25-50mm) gap exists between recoil dampener and hammer base plate (160451).

See FIG 3, Page II-7, for location of recoil dampener

T. CHECKING & REPLACING CUSHION MATERIAL

With new cushion material, the striker plate flange should be 2" (45mm) above the top of a DCB-1 Drive Cap (32" leads). If this dimension is reduced by more than 1/2"(13mm), replace the cushion material.

See Section II F Page II-6 ATTACHMENT OF DRIVECAP for instructions on replacing cushion material.



**MODEL 220
HYDRAULIC
IMPACT HAMMER**

V. HYDRAULIC CIRCUITRY

A. DRIVE PUMP

With the diesel engine running, hydraulic oil is taken from the reservoir by the drive pump (P1). The drive pump flow returns to the reservoir as long as the drive switch remains in its NEUTRAL position.

Turning the FORWARD/REVERSE switch to FORWARD operates the DIRECTIONAL CONTROL VALVE (V2) directing the pump flow to the hammer through a 1.25" hose. Hammer operating pressure is indicated by the drive PRESSURE GAGE (GA1). Maximum drive pressure is limited to approximately 4540 PSI (303 Bar) by the drive pressure RELIEF VALVE (RV1). The quick-disconnect couplings (QD1 and QD2) permit de-coupling of the drive hoses at the power unit.

The CONTROL VALVE (V3), in the hammer, sends the pump flow directly to the lower (rod end) of the CYLINDER (CYL). The CONTROL VALVE also sends pressure to the DUMP VALVE (DV) holding it closed. The ram lifts. Additional hydraulic oil, stored under pressure in the PRESSURE ACCUMULATOR (A1), adds to the pump flow causing an upward velocity of the ram that is greater than the pump flow, alone, would generate. As the CYLINDER raises the ram, oil in the upper (blind end) of the CYLINDER is exhausted back to the power unit through a 1.50" return hose. Flow resistance in the return hose causes a portion of this exhaust flow to be, temporarily, stored in the TANK ACCUMULATOR (A2).

As the ram nears the top of its stroke, the trip bar activates the TRIP VALVE (V4), which is hydraulically connected to the main pump flow via check valve CV6. Activating the TRIP VALVE directs a pressure signal to shift the CONTROL VALVE (V3). Pump flow is disconnected, and blocked, from the rod end of the CYLINDER when the CONTROL VALVE shifts. Shifting the CONTROL VALVE also removes pressure from the DUMP VALVE, which opens, and allows the ram to fall. High upward velocity of the ram, however, causes it to continue upward movement, decelerating, even after the DUMP VALVE is opened. While the CYLINDER is decelerating to a stop, the rod end is kept full of oil by REPLENISHMENT CHECK valve (CV4).



**MODEL 220
HYDRAULIC
IMPACT HAMMER**

V. HYDRAULIC CIRCUITRY

A. DRIVE PUMP (CONTINUED)

After the upward movement of the ram stops, it begins to fall because the DUMP VALVE is already open. While the ram is falling, and during the deceleration phase of the cycle, pump flow is stored in the PRESSURE ACCUMULATOR. While the ram is falling, the CONTROL VALVE is held in its shifted position by a pilot signal generated by the DUMP VALVE. Oil exiting the DUMP VALVE, at high speed, goes directly to the blind end of the CYLINDER and does not restrict the downward movement of the ram. When the ram impacts the pile, the downward movement of the cylinder stops, and the pilot signal is removed from the CONTROL VALVE. A spring returns the CONTROL VALVE to its normal (lift) position, and another lift cycle begins. The CYLINDER will continue cycling, as described above, until the DIRECTIONAL CONTROL VALVE (V2) is de-energized by returning the FORWARD/REVERSE switch to the NEUTRAL position. When the trip valve is activated by the trip bar, a pilot pressure signal is sent to the CONTROL VALVE (V3) pilot piston, shifting the CONTROL VALVE. The balance of the cycle is the same as in the long stroke position, above.

B. STROKE CONTROL PUMP

With the diesel engine running, hydraulic oil is taken from the reservoir by the stroke control pump (P2). The stroke control pump oil returns to the reservoir if the clamp switch is in the NEUTRAL position. Returning oil is filtered by the return filter (F2).

Turning the clamp switch to CLOSE retracts the variable stroke cylinder (CLY2). Returning the switch to neutral allows the hammer to run at that stroke length. Turning the clamp switch to OPEN momentarily, extends the variable stroke cylinder (CLY2). Pressure is indicated by the pressure gage (GA-2). Pilot pressure in the stroke control circuit is limited to 1500 PSI (103 Bar) by the STROKE RELIEF valve (RV2). Adequate pressure to extend and retract the variable stroke cylinder is insured by relief valve (RV2).

The quick-disconnect coupler (QD3 and QD4) permits de-coupling of the stroke control hose at the power pack.



**MODEL 220
HYDRAULIC
IMPACT HAMMER**



**MODEL 220
HYDRAULIC
IMPACT HAMMER**

V. HYDRAULIC CIRCUITRY

C. OTHER

Returning oil is filtered by the return filters (F2) before entering the reservoir. INDICATOR GAGE (GA5) shows condition of FILTER (F2).

The shut-off VALVE (MV1) may be closed to permit removal of the pumps (P1 and P2) without draining the reservoir. CAUTION: DO NOT start engine with MV1 closed.

The oil cooler (HE) cools the hydraulic oil returning from the hammer.

65 PSI Check VALVE (CV5) prevents excess pressure from damaging HEAT EXCHANGER (HE).

A manual pump (MP) is provided to fill the hydraulic reservoir. A CHECK VALVE (CV2) prevents loss of oil from the reservoir back through the manual pump.

A temperature switch (TS) located in the reservoir operates the hydraulic oil cold light.

Check valve CV8 and orifice OF2 control the movement of the DUMP VALVE, allowing rapid closing and slower opening.

CONTROL VALVE orifice OF1 provides controlled leakage of pilot signals.

Check valve CV7 prevents loss of pilot pressure signal into the CONTROL VALVE.



MODEL 220 HYDRAULIC IMPACT HAMMER

V. HYDRAULIC CIRCUITRY

HYDRAULIC SCHEMATIC

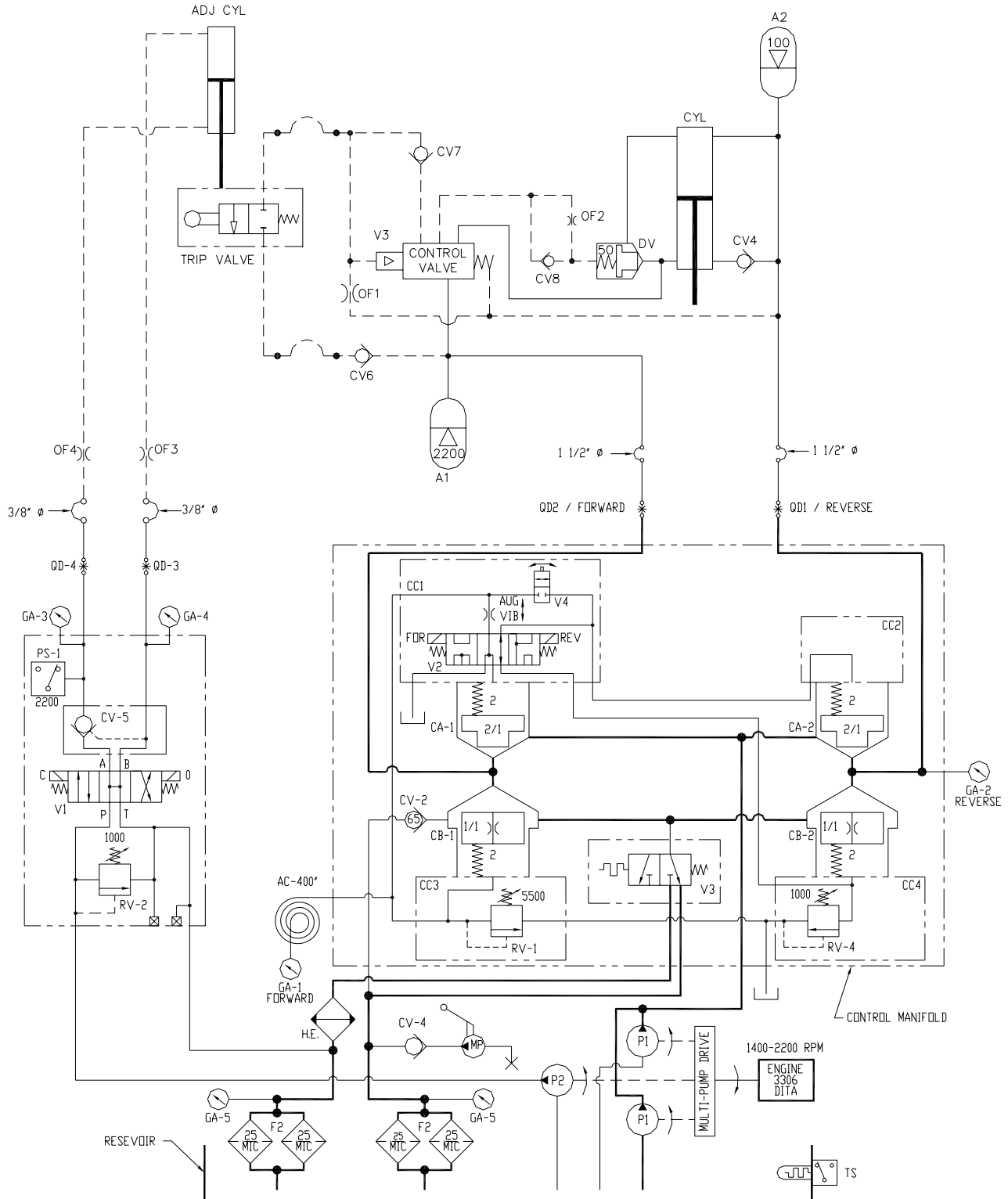



**MODEL 220
HYDRAULIC
IMPACT HAMMER**

V. HYDRAULIC CIRCUITRY

D. HYDRAULIC COMPONENT LIST

<u>Notation</u>	<u>Description</u>	<u>Part Number</u>	<u>Page Number</u>
A1	Pressure accumulator	160467	VIII-11
A2	Tank accumulator	160467	VIII-11
CV1	Clamp check valve	110149	VIII-45
CV2	Manual pump check valve	100451	VIII-37
CV4	Replenishment check valve	810683	VIII-20
CV5	Bypass check valve	130339	VIII-43
CV6	Trip valve supply check valve	160323	VIII-16
CV7	Control valve check valve	160323	VIII-19
CV8	Dump valve check valve (in cover)	160323	VIII-16
CYL	Ram lifting (Actuator) cylinder	810795	VIII-14
CYL2	Variable stroke cylinder	160817	VIII-11
DV	Dump valve	810701	VIII-21
E	Diesel engine	170239	VIII-36
F1	Pick-up filter	400087	VIII-39
F2	Return filter (4)	100518	VIII-36
GA-1	Drive pressure gage	150079	VIII-31
GA-2	Close clamp pressure gage	150079	VIII-31
GA-3	Open clamp pressure gage	150079	VIII-31
GA-4	Return filter gage	100436	VIII-39
HE	Oil Cooler	400099	VIII-36
MP	Manual Pump	100447	VIII-37
MV1	Shut-off valve	400117	VIII-38
OF1	Control valve orifice	810777	VIII-19
OF2	Dump valve orifice	810777	VIII-17
P1	Drive Pump	170309	VIII-36
P2	Stroke control pump	170393	VIII-36
PS1	Clamp pressure switch	810033	VIII-45
QD1	Hammer return disconnect	110690	VIII-36
QD2	Hammer pressure disconnect	110692	VIII-36
QD3	Shorten stroke disconnect	100777	VIII-38
QD4	Lengthen stroke disconnect	100245	VIII-38
RV1	Drive relief valve	400742	VIII-43
RV2	Stroke relief valve	100898	VIII-45
TS	Temperature switch	400115	VIII-38
V1	Stroke control valve	110147	VIII-45
V2	Directional control valve	400786	VIII-43
V3	Control valve	810621	VIII-18
V4	Trip valve	810815	VIII-11



**MODEL 220
HYDRAULIC
IMPACT HAMMER**

VI. ELECTRICAL CIRCUITRY

A. DIESEL ENGINE

The BATTERY provides 24 volt current to start the diesel engine. With the FORWARD-REVERSE switch turned to OFF, turning the ENGINE START SWITCH to START energizes the START RELAY which energizes the START MOTOR and turns over the diesel engine. If fuel is available, the diesel engine will start. In order for fuel to be available to the engine, the SHUTDOWN RESET must be closed to energize the FUEL SOLENOID. The FUEL SOLENOID opens the fuel rack and allows fuel to flow to the engine. With the diesel engine running, the AMMETER indicates charging amperes. The HOUR METER indicates engine operating hours.

The MAIN POWER (CB2) switch, when in the ON position, provides electrical power to the balance of the power unit and hammer controls. The MAIN POWER switch is also a circuit breaker, providing over current protection to the electrical system. Turning the MAIN POWER switch to the OFF position disables the pendant and power unit controls. Turning OFF the MAIN POWER switch DOES NOT disable the safety shut down system (SHUTDOWN RESET) or the engine HOUR METER.

A system of safety controls shuts off the fuel supply, thereby stopping the diesel engine, in the event that engine water temperature is too high or engine oil pressure is too low. The heart of the safety system is the SHUTDOWN RESET which is normally closed, thereby providing current to operate the HOUR METER and to energize the fuel rack and allows fuel to flow to the diesel engine. The SHUTDOWN RESET must remain closed so that fuel continues to flow to the diesel engine.

If the coil in the SHUTDOWN RESET is momentarily energized, the SHUTDOWN RESET will open shutting off the fuel to the diesel engine. The engine will stop. The coil may be energized by any one of the following devices:

1. Engine Oil Pressure Gage - If oil pressure is below 15 PSI (1 Bar), the contacts of the gage will be closed providing current to energize the coil. On start-up, the reset button of the SHUTDOWN RESET (on the control panel) must be held until oil pressure exceeds 30 PSI (2 Bar).
2. Engine Water Temperature Gage - If water temperature exceeds 210°F (99°C), the contacts of the gage will close energizing the SHUTDOWN RESET coil.
3. Emergency Stop: - Pressing the emergency stop button, on the remote pendant, will energize the SHUTDOWN RESET coil.

The diesel engine is stopped by turning the ENGINE START SWITCH to OFF. This will de-energize the FUEL SOLENOID shutting off the fuel to the engine. Turning the ENGINE START SWITCH to OFF also disconnects all other electrical circuits.



**MODEL 220
HYDRAULIC
IMPACT HAMMER**

VI. ELECTRICAL CIRCUITRY

B. STROKE RANGE SELECT

With the diesel engine running and the MAIN POWER switch ON, turning the Clamp switch (OPEN-CLOSE) to OPEN energizes the open-clamp solenoid (OPEN SOL). This extends the variable stroke cylinder, fully extending this cylinder puts the hammer in minimum stroke mode. Release the switch to the neutral position, for regular operation. This is the recommended starting position.

With the diesel engine running and the MAIN POWER switch ON, turning the Clamp switch (OPEN-CLOSE) to CLOSE energizes the close-clamp solenoid (CLOSE SOL) on the clamp valve (V1). This retracts the variable stroke cylinder, fully retracting this cylinder puts the hammer in full stroke mode. Returning the switch to the neutral position. De-energizes the close clamp solenoid and holds the stroke control cylinder at the desired position.

Adjusting the position of the variable stroke cylinder to where the stroke length most adequately suits the job conditions. This can be done at any time as described above.

NOTE: The pressure switch (PS1) shown in the stroke control portion of the electrical schematic is not used in the operation of the Model 220 hydraulic impact hammer. The adjustment of this switch should remain at the setting required for a Vibratory Driver/Extractor.

C. HYDRAULIC HAMMER

With the diesel engine running and the MAIN POWER switch ON, turning the hammer switch (FORWARD-REVERSE) to FORWARD energizes the hammer-start solenoid (V2A) on the DIRECTIONAL CONTROL valve. The DIRECTIONAL CONTROL valve shifts, sending hydraulic oil to the hammer and the hammer begins to run. Turning the hammer switch to the OFF position will stop the hammer from lifting again.

D. REMOTE - LOCAL CONTROL

Located on the control panel. Turning the LOCAL-REMOTE switch to LOCAL activates only the hammer and stroke control switches located on the control panel. Turning the LOCAL-REMOTE switch to REMOTE only permits operation of the hammer from the control pendant. The EMERGENCY STOP button, on the pendant, is functional at all times.



**MODEL 220
HYDRAULIC
IMPACT HAMMER**

VI. ELECTRICAL CIRCUITRY

E. ENGINE THROTTLE

The ENGINE THROTTLE switch is located on the remote pendant. With the diesel engine running, the MAIN POWER switch ON and the REMOTE-LOCAL switch in the REMOTE position, momentarily turning the ELECTRIC THROTTLE switch to the FAST position will retract the motor driven throttle actuator and increase engine RPM. Turning the ELECTRIC THROTTLE switch to SLOW will extend the motor driven throttle actuator decrease engine RPM

F. TACHOMETER

The TACH SENDER generates an electrical pulse every time a flywheel gear tooth passes this sensor. This high frequency signal is converted to a visual indication of engine RPM by the TACHOMETER GAGE (TACH). The MAIN POWER switch must be ON and the engine running for the TACH to function.

G. OTHER

With the MAIN POWER switch ON, if the temperature of the hydraulic oil is below 60°F(16°C), the TEMPERATURE SWITCH closes and the HYDRAULIC OIL COLD light comes on. When the temperature of the hydraulic oil exceeds 60°F(16°C), the TEMPERATURE SWITCH turns off the HYDRAULIC OIL COLD light.



MODEL 220 HYDRAULIC IMPACT HAMMER

VI. ELECTRICAL CIRCUITRY

ELECTRICAL LAYOUT

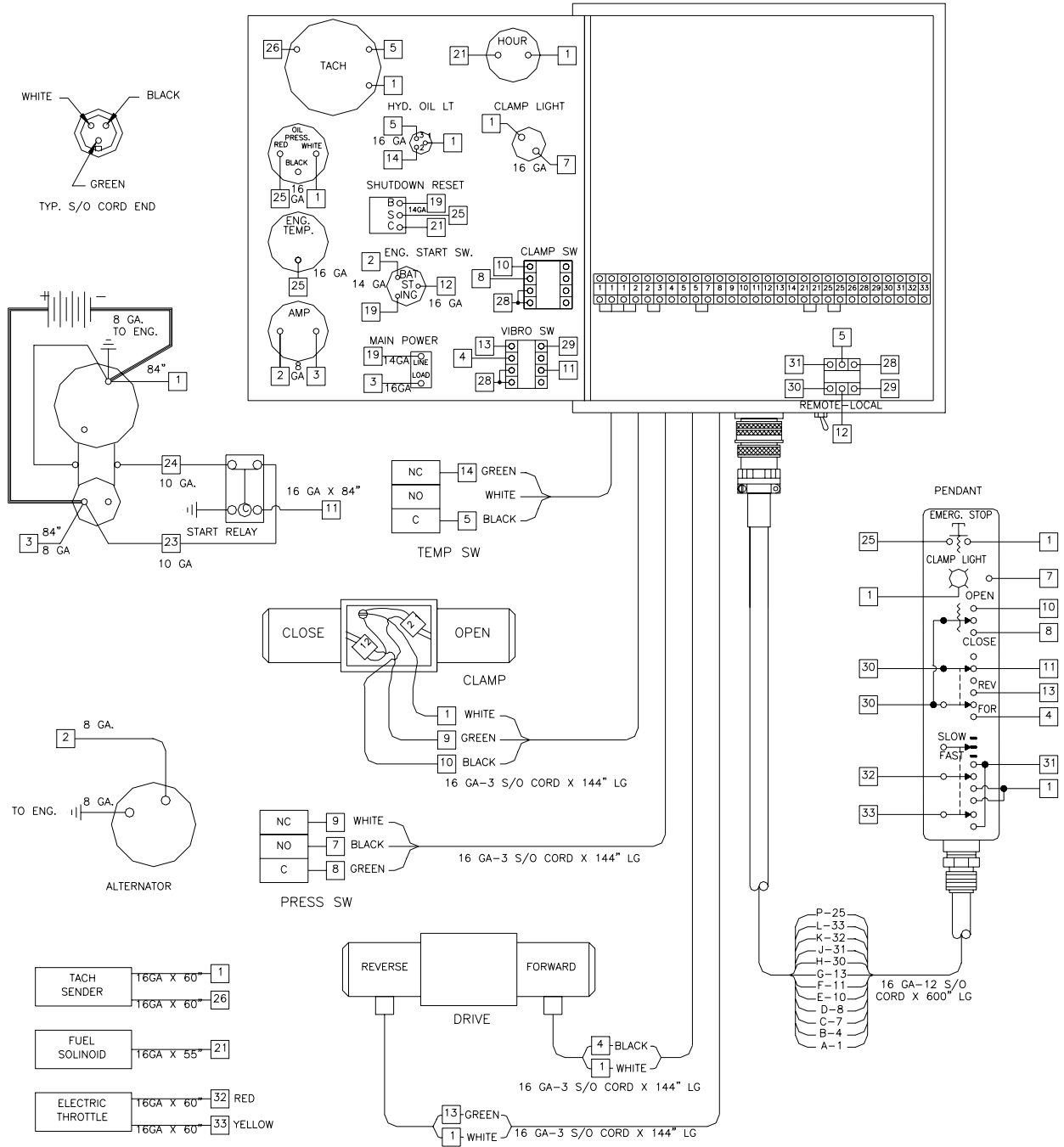



**MODEL 220
HYDRAULIC
IMPACT HAMMER**

VI. ELECTRICAL CIRCUITRY

ELECTRICAL SCHEMATIC

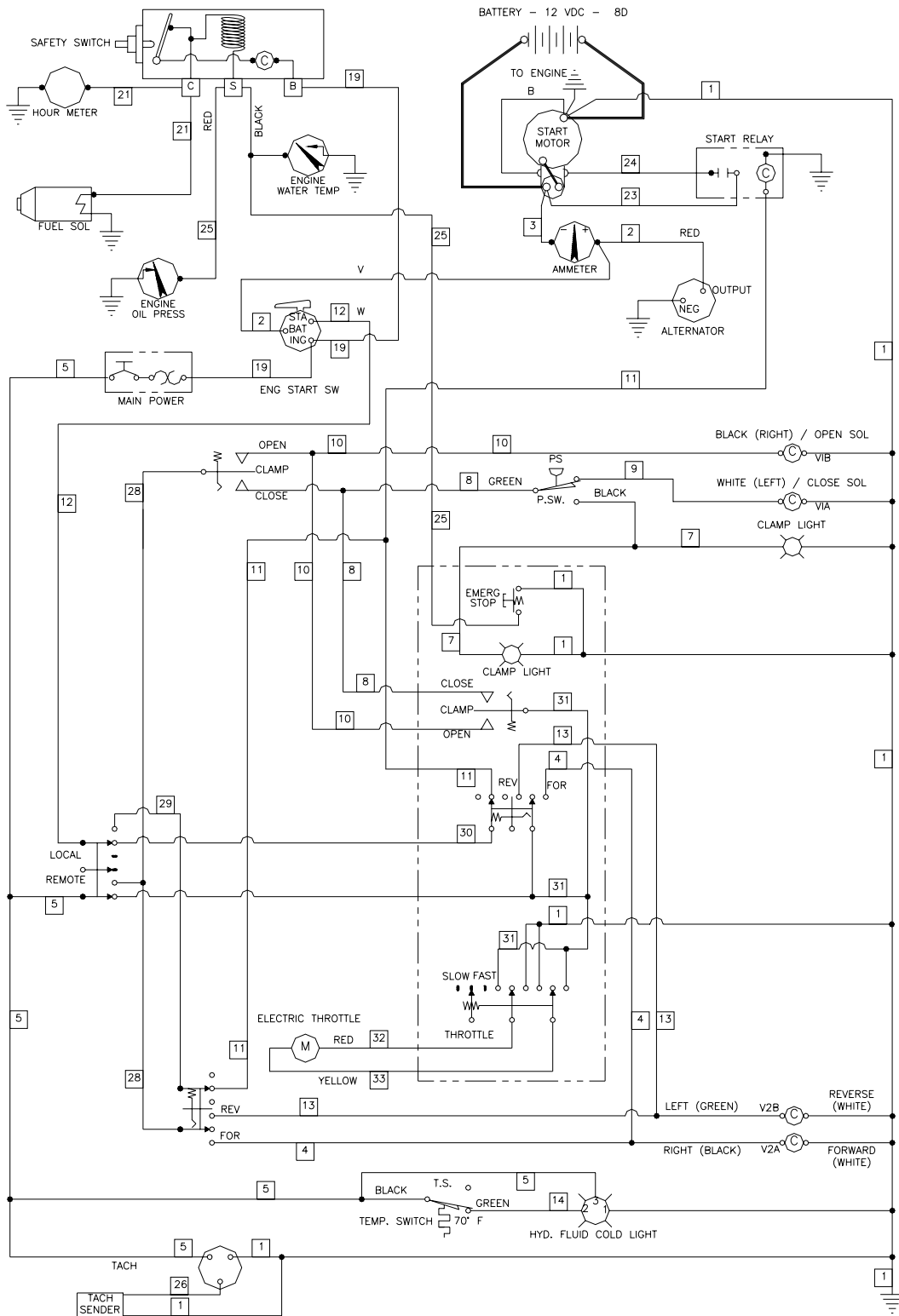



**MODEL 220
HYDRAULIC
IMPACT HAMMER**

VI. ELECTRICAL CIRCUITRY

H. ELECTRICAL COMPONENTS LIST

<u>NOTATION</u>	<u>REFERENCE</u>	<u>PART NUMBER</u>
ALTERNATOR	Battery charging alternator	See Caterpillar Parts Book
AMMETER	Ammeter	110371
BATTERY	12-volt battery	400890
CLAMP LIGHT	Clamp closed light (Vibro only)	
CLOSE SOL.	Close-clamp solenoid	110147
EMERG STOP	Emergency stop button	130507
ENGINE OIL PRESS	Engine oil pressure switch and gage	100329
ENGINE WATER TEMP	Engine water temperature switch and gage	130251
ENG. START SW.	Engine start switch	130259
FORWARD	Hammer start solenoid	400786
FUEL SOL	Fuel valve solenoid	See Caterpillar Parts Book
HOUR METER	Hour Meter	100343
HYD. FLUID COLD	Hydraulic oil warning	100355
LOCAL-REMOTE	Local/remote switch	140361
M	Engine throttle actuator	110246
MAIN POWER	Main power circuit breaker	400141
OIL PRESSURE	Oil pressure gage-switch	100329
OPEN-CLOSE	Clamp switch	130155
OPEN SOL.	Open-clamp solenoid	130033
PS	Pressure Switch	810033
REVERSE	Vibrator stop solenoid (Auger only)	400786
SHUTDOWN RESET	Engine Saftey Shutdown	130257
START MOTOR	Engine starter	See Caterpillar Parts Book
START RELAY	Engine start relay	See Caterpillar Parts Book
TACH	Tachometer gage	130953
TACH SENDER	Tachometer flywheel pickup	130959
TEMP SWITCH	Temperature switch	400115
THROTTLE	Engine throttle switch	100566

Bill of Materials for: 800539**04/05/2007**

Drawing # 800539

220 HIH FINAL ASSEMBLY

Item No	Component ID	Component Description	Quantity	Drawing #	Info Only
1	160425	LEFT LIFTING BALE	1	160425	
2	160453	TOP PLATE	1	160453	
3	810797	220 ACTUATOR ASSEMBLY	1	810797	
4	160489	.75-10UNC X 9.00 LG SHCS	6		
5	160881	TRIP BAR BUSHING	1	160881	
6	160285	.50 BELLEVILLE WASHER	2		
7	100445	.5-13 X 1.0 LG SHCS LOC WEL	2		
8	160992	GUIDE POST 160B / 220	4	160992	
9	810805	RAM 220	1	810805	
10	100209	1.00 LOCK WASHER MEDIUM	24		
11	160955	3.25-12 SUPERNUT	1		
12	160998	BACK-UP RING 220	2	160998	
13	160996	ELASTOMER 220	2	160996	
14	160993	RAM CONN TOP PLATE	1	160993	
15	160995	RAM CONN BOTTOM PLAE 220	1	160995	
16	160997	ROD FLANGE 220	1	160997	
17	160999	NYLON INSERT 220	2	160999	
18	100717	FITT2L-06P04M000-0000001	2		
19	810813	ORIFICE PLUG	2	810813	
20	160922	1.00-8UNC X 6.50 LG SHCS	12		
21	160949	TRIP CYLINDER 36in	1		
22	160953	TRIP BAR 220	1	160953	
23	810815	TRIP VALVE MODIFIED	1		
24	100121	.50 LOCK WASHER MEDIUM	14		
25	160990	WIRE ROPE ASM 160B / 220	4	160990	
26	120521	SPRING PIN .375 x 2.0 LG	4		
27	160821	HOSE CLAMP	2		
28	160451	BASE PLATE	1	160451	
29	160823	BRASS BUSHING	2		
30	160447	COLUMN BEARING	8	160447	
31	160825	TRIP LEVER	1	160825	
32	810811	ORIFICE FITTING	2	810811	
33	160495	ROLL PIN .750 x 150 LG	4		
34	160994	SHEAVE BRACKET 160B / 220	1	160994	
35	100213	1.0-8 X 2.50 LG SHCS LOC WEL	24		
36	810659	CENTERING NUT	4	810659	
37	160471	3.00 H FINISH HEX NUT	4		
38	160467	ACCUMULATOR	2	160467	
39	160475	ACCUMULATOR BRACKET	8	160475	
40	160433	ACCUMULATOR MANIFOLD	2	160433	
41	160477	HOSE150PT4F024J924L0212C	1		

Bill of Materials for: 800539**04/05/2007****Drawing # 800539****220 HIH FINAL ASSEMBLY**

Item No	Component ID	Component Description	Quantity	Drawing #	Info Only
42	160479	HOSE150PT4M024F024L0722C	1		
43	100596	#24 SPLIT FLANGE HALF	14		
44	130321	.75 X .75 BAR PER IN	8		
45	100163	.5-13 X 1.75 LG SHCS LOC WEL	4		
46	160875	SLIDE	1	160875	
47	160877	RETAINER PLATE	2	160877	
48	160419	SHEAVE PIN	1	160419	
49	160481	HOSE150PT4F924F024L0592C	1		
50	100631	.25-20 X 2.0 LG SHCS	4		
51	160935	CYLINDER PIN	2		
52	400037	.75-10 x 1.25 LG SHCS	4		
53	100027	.5 HI-COLLAR LOCK WASHER	8		
54	160483	HOSE150PT4J024F024L0585C	1		
55	160209	ELASTOMER BRACKET	1	160209	
56	400069	.75-10 x 2.0 LG SHCS	4		
57	100069	.75 LOCK WASHER MEDIUM	12		
58	100587	.75-10 HEX NUT	4		
59	100796	ELASTOMER	1		
60	160211	CLAMP MOUNTING PLATE	1	160211	
61	160469	SHEAVE	1		
62	100009	HOSE CLAMP	1	100009	
63	160793	BELLEVILLE WASHER	4		
64	100015	HOSE CLAMP	2	100015	
65	130117	.375 X1.5 LG SHCS	4		
66	160905	1.00-8UNC FLEX-LOCK NUT	1		
67	100005	.625-11 X 1.75 LG SHCS LOC WELL	4		
68	100007	.625 LOCK WASHER MEDIUM	8		
69	100273	.625-11 HEX NUT	4		
70	100299	PRIMER/GAL	2		
71	100298	APE / J&M YELLOW PAINT/GAL	2		
72	100575	.625-11 x 1.25 LG SHCS	5		
73	160427	RIGHT LIFTING BALE	1	160427	
74	100559	.25 LOCK WASHER	4		
75	100719	HOSE025R02J004J004L03000	1		
76	160886	TRIP LEVER SPRING	1		
77	110119	2-225 O-RING	2		
78	130049	.5-13 ESNA NUT	16		
79	160869	CYLINDER SUPPORT	1	160869	
80	160457	BUMPER	1	160457	
81	160485	HOSE150PT4F924F024L0706C	1		
82	100119	.5-13 X 1.25 LG SHCS LOC WEL	12		

Bill of Materials for: 800539**04/05/2007****Drawing # 800539****220 HIH FINAL ASSEMBLY**

Item No	Component ID	Component Description	Quantity	Drawing #	Info Only
83	110057	1.5 SOLID FLANGE	2		
84	160557	FITT2V-20P20N000-0000001	1		
85	400159	FITT2S-24P20Q000-000H001	1		
86	160493	FITT2V-06P06N000-0000001	2		
87	300447	.1875 X 2 LG COTTER PIN	4		
88	160501	.50-13UNC X 10.00 LG FHCS	8		
89	100079	.5-13 X 4.0 LG SHCS	8		
90	100829	.5-13 X3.5 LG SHCS	8		
91	160804	2-225 FACE SEAL	9		
92	160503	FITT2P-20R000000-0000001	2		
93	160865	2in U-BOLT	1		
94	160867	.44-14UNC HEX NUT	4		
95	130057	FITT2L-06M06R000-000H001	2		
96	120299	1.00 H. S. FLAT WASHER	3		
97	140905	HOSE038R02J006J006L0835C	2		
98	160549	TOP BUMPER	2	160549	
99	100443	.437 LOCK WASHER	2		
100	810761	MODIFIED 1-8UNC X 8.0 SHCS	1	810761	
101	100513	.5-13 X 1.5 LG SHCS	6		
102	300089	.375-16 X 4.0 LG SHCS	1		
103	110317	HOSE CLAMP	1	110317	
104	400149	.375 LOCK WASHER	1		
105	100762	.375-16 UNC ESNA NUT	2		
106	100067	.75-10 X 2.5 LG SHCS LOC WEL	2		
107	110913	.38-16 X 3.00LG SHCS	4		
108	160909	NYLON WASHER	1	160909	
109	160911	URETHANE BUSHING	1	160911	
110	160913	TRIP BAR ANCHOR	1	160913	
111	160915	PIN	2	160915	
112	160917	SPRING PIN .19DIA X 1.25 LG	4		
113	100011	.50-13 UNC X 2.00 LG SHCS	8		
114	160559	FITT2V-24P24N000-0000001	1		
115	160975	INSERT SPACER	12	160975	
116	160759	220 SERIAL NUMBER PLATE	1	160759	
117	130381	RIVET	4		
118	100229	GREASE FITTING	1		
119	100827	.375-16 X 3.5 LG. SHCS	1		
121	160383	STRIKE BLOCK	1	160383	
122	160455	RECOIL DAMPNER	1	160455	
123	170661	HOSE025R02J004J004L04700	1		
124	LABOR	HALF HOURS	100		

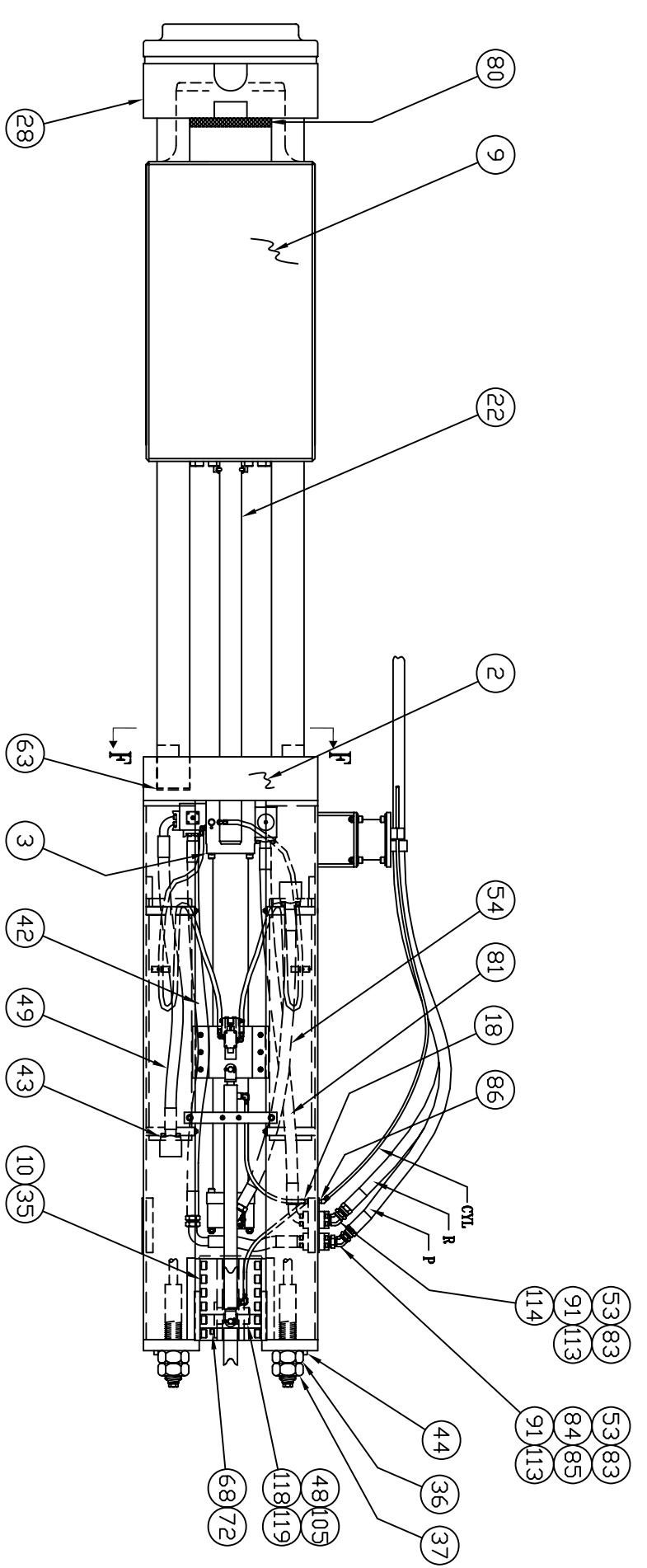

NOTE:
 1. USE THE CLOSE CLAMP PRESSURE PORT TO RETRACT CYLINDER FOR LONG STROKE.

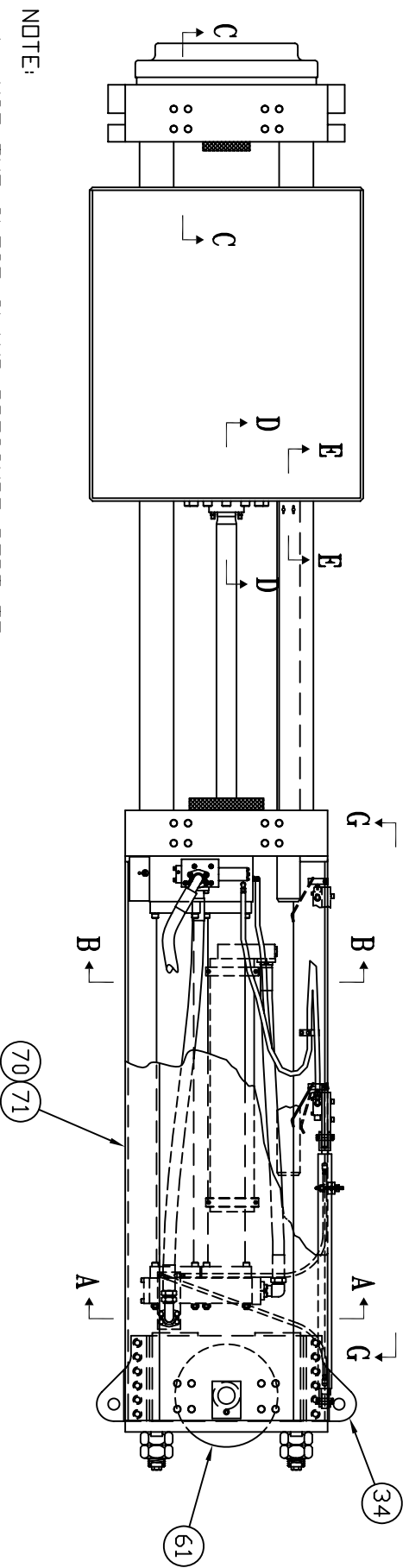

MATERIAL:

SCALE: 1:30

DWN. BY: SEG	DATE: 6-17-99	MODEL: 220 HIH	DESCRIPTION FINAL ASSEMBLY	VIEW M	FOUNDATION EQUIPMENT LLC PITTSBURGH, PENNSYLVANIA
-----------------	------------------	----------------	-------------------------------	-----------	--

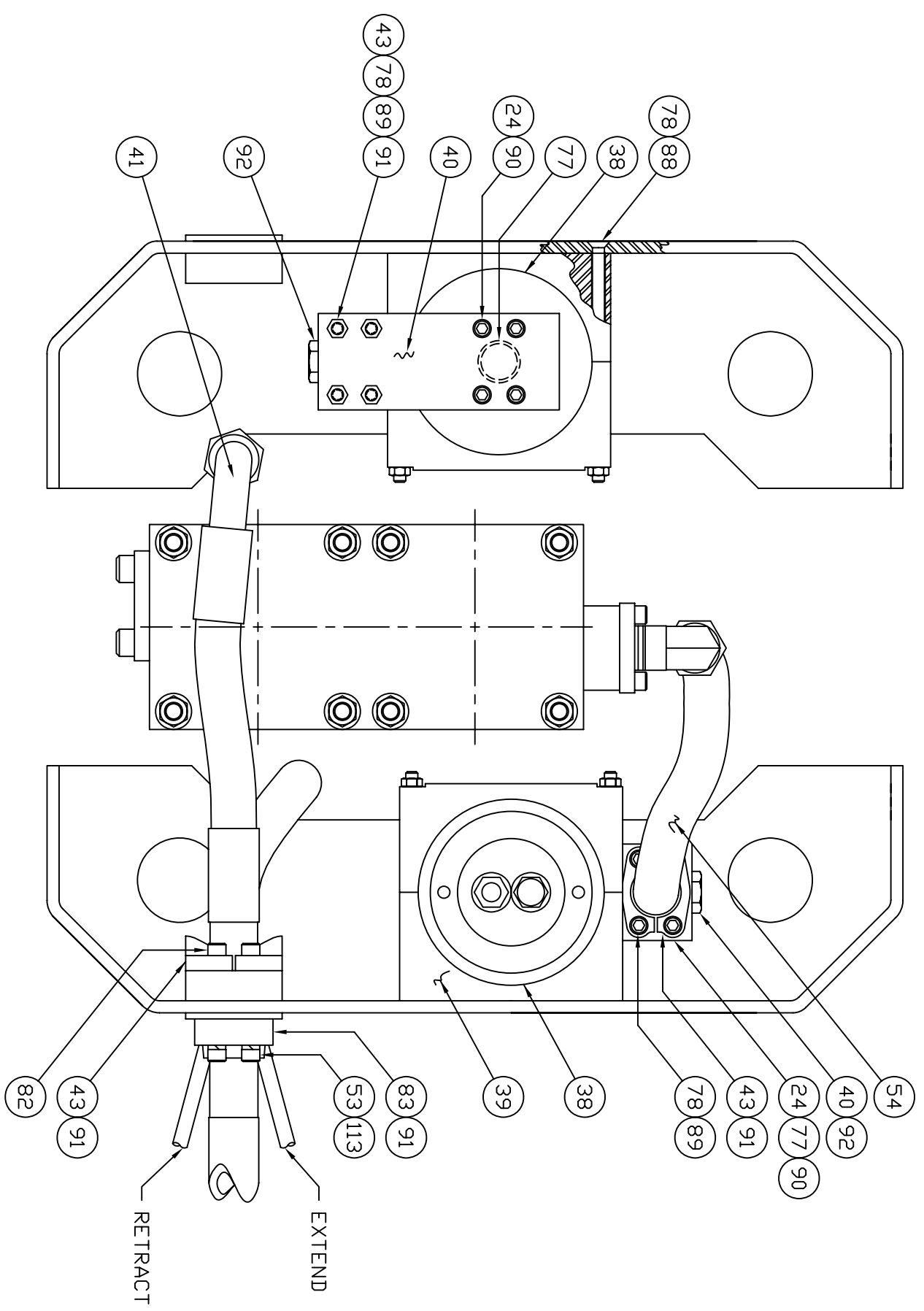

DWN. BY: DATE: 6-17-99 MODEL: 220 HIH
 DESCRIPTION: FINAL ASSEMBLY VIEW: A
 SCALE: 1:6
 FOUNDATION EQUIPMENT LLC
 PITTSBURGH, PENNSYLVANIA

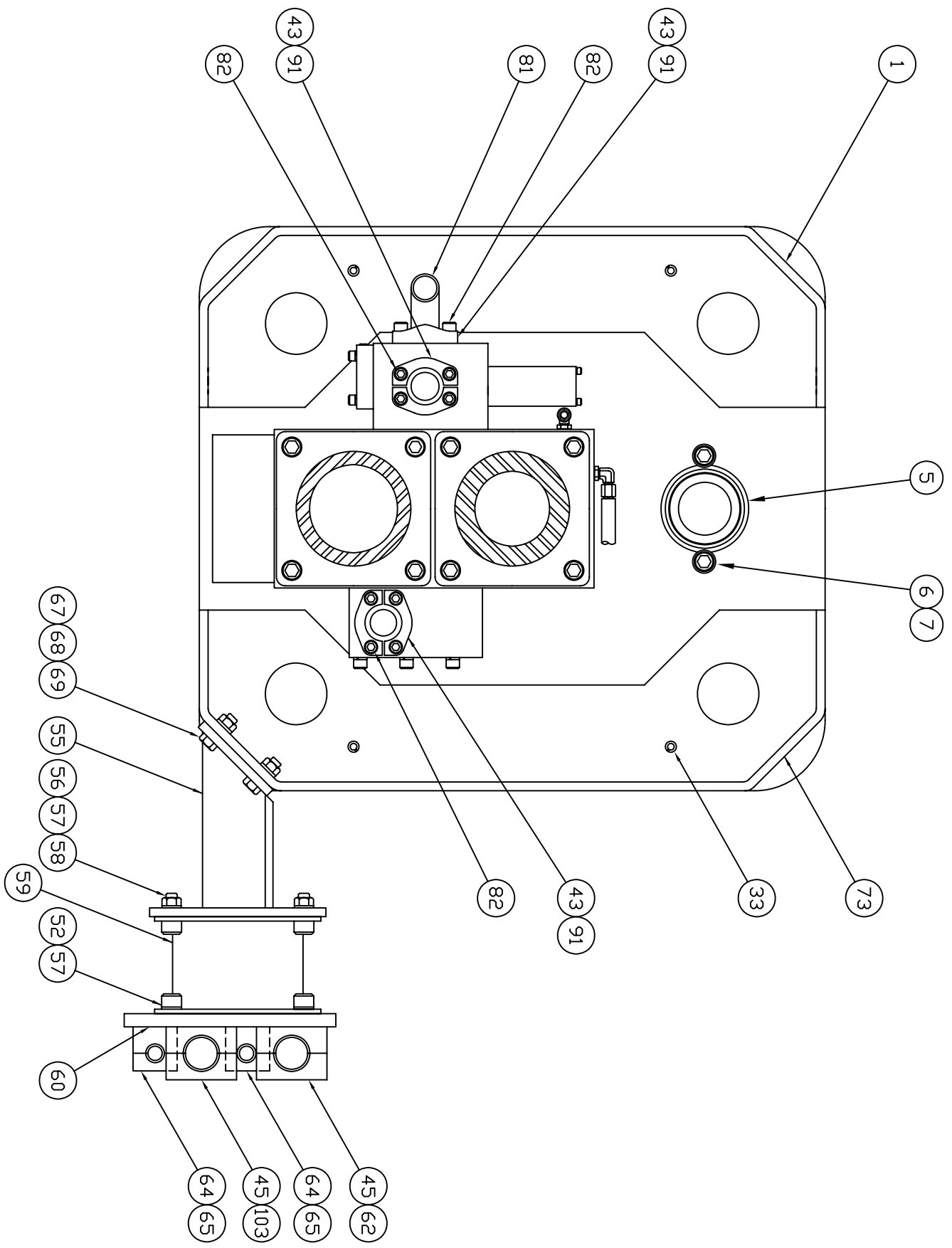

MATERIAL:

SCALE: 1:8

DWN. BY: SEG	DATE: 6-17-99	MODEL: 220 HIH	DESCRIPTION FINAL ASSEMBLY	VIEW B	FOUNDATION EQUIPMENT LLC PITTSBURGH, PENNSYLVANIA
-----------------	------------------	----------------	-------------------------------	-----------	--

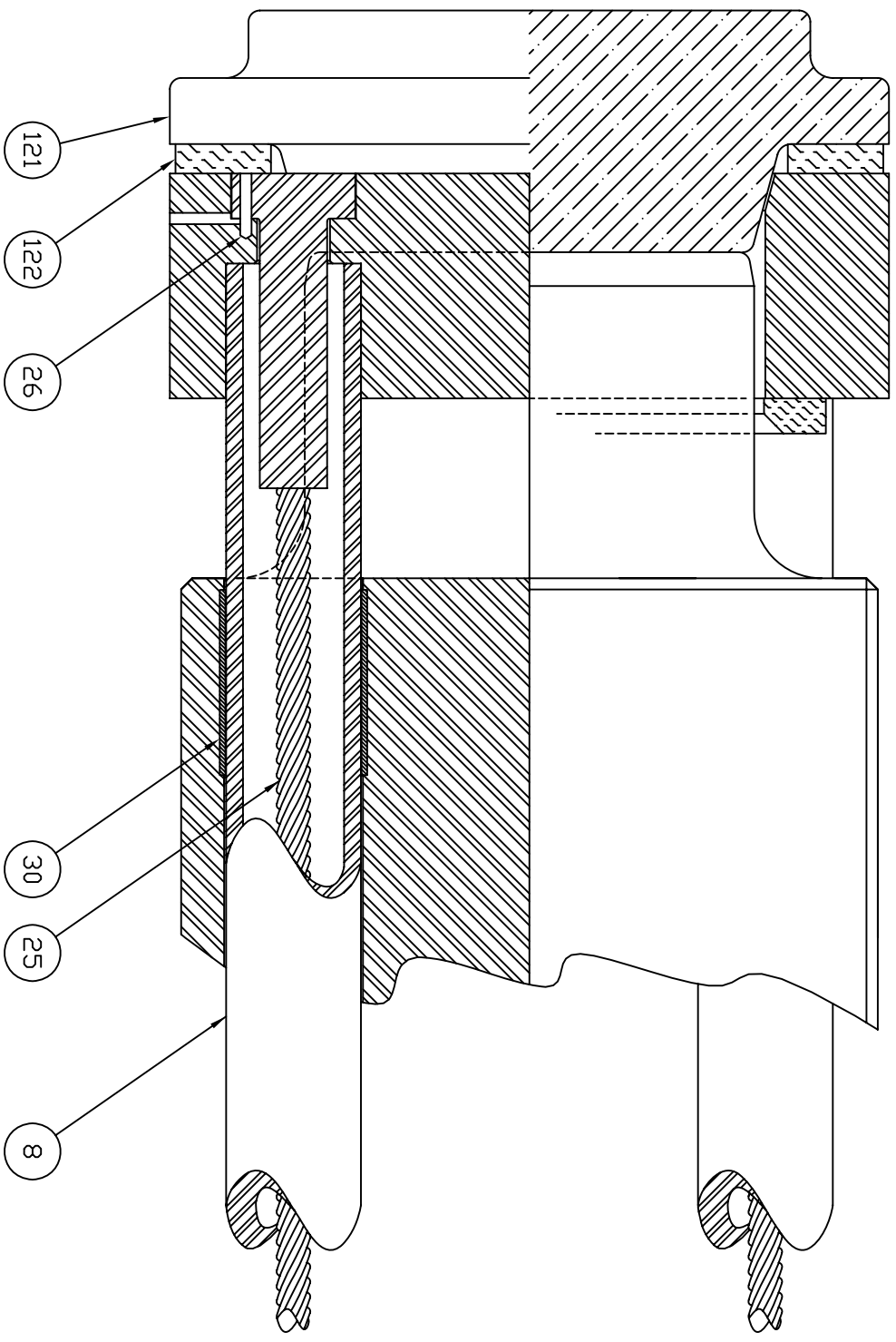

MATERIAL:

SCALE: 1:8

DWN. BY: SEG	DATE: 6-17-99	MODEL: 220 HIH	DESCRIPTION FINAL ASSEMBLY	VIEW C	FOUNDATION EQUIPMENT LLC PITTSBURGH, PENNSYLVANIA
-----------------	------------------	----------------	-------------------------------	-----------	--

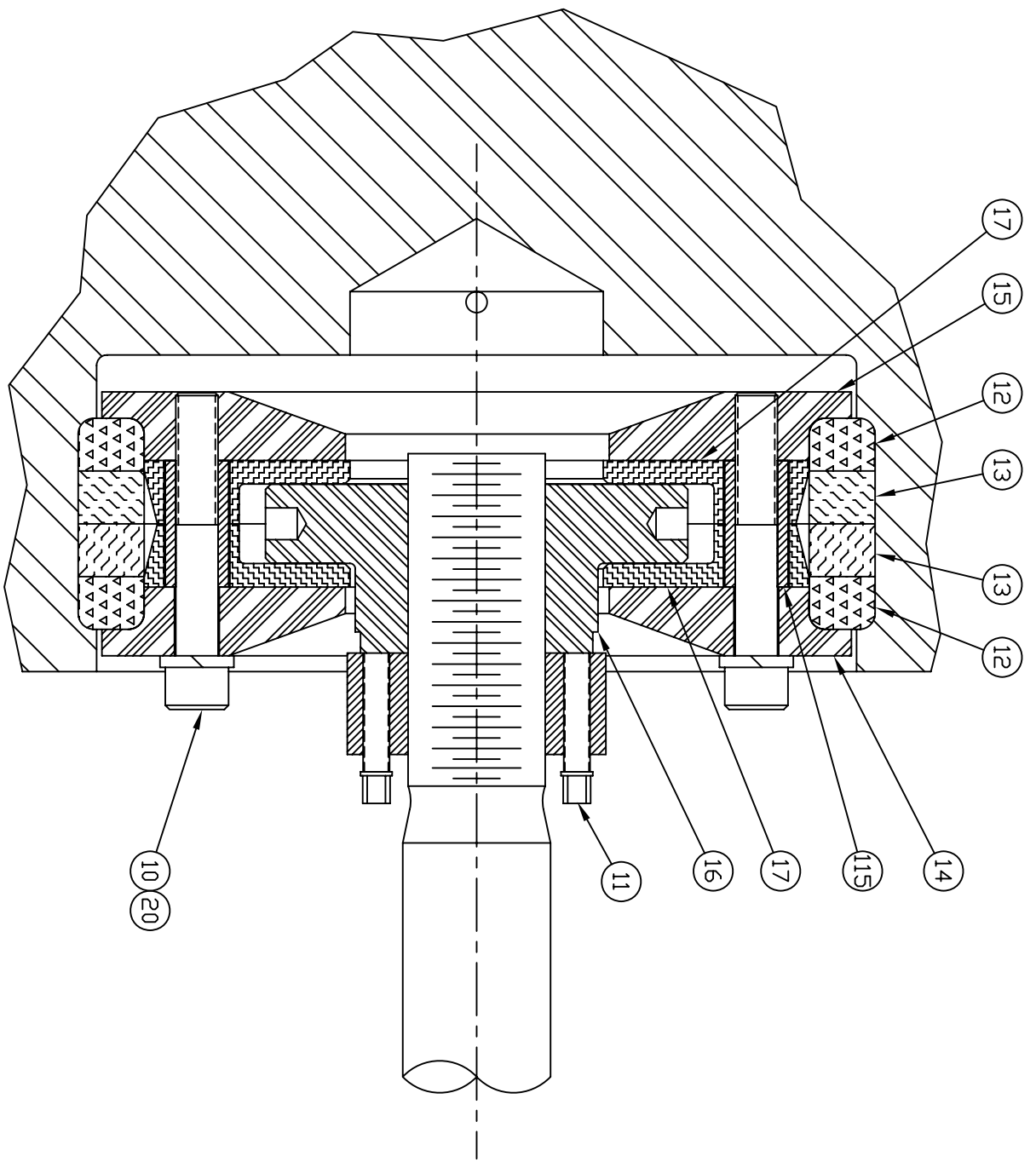

MATERIAL:

SCALE: 1:4

DWN. BY: DATE: 6-17-99

MODEL: 220 HIH

DESCRIPTION FINAL ASSEMBLY

VIEW D



FOUNDATION EQUIPMENT LLC
PITTSBURGH, PENNSYLVANIA

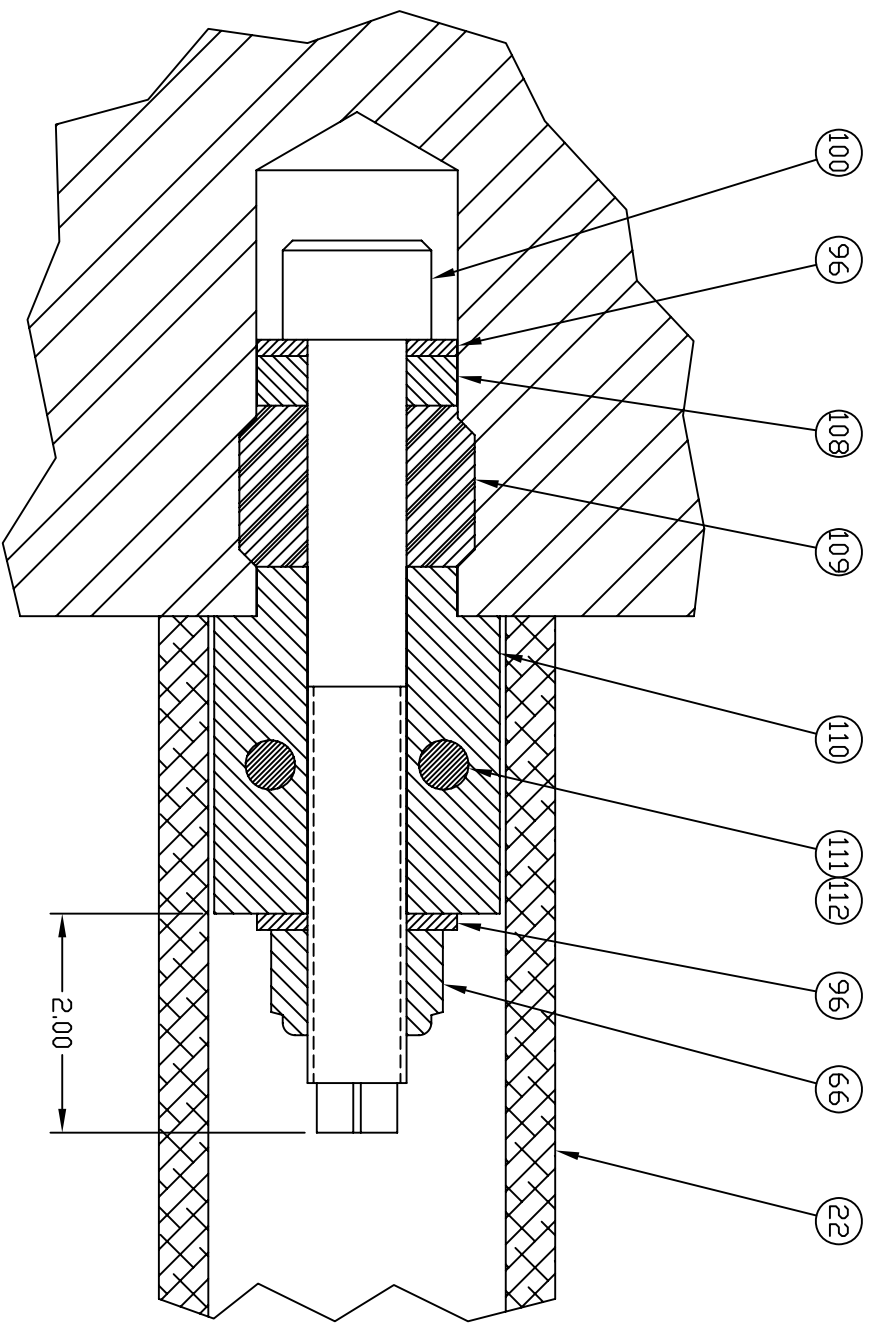

MATERIAL:

SCALE: 1:2

DWN. BY: SEG	DATE: 6-17-99	MODEL: 220 HIH	DESCRIPTION FINAL ASSEMBLY	VIEW E	 FOUNDATION EQUIPMENT LLC PITTSBURGH, PENNSYLVANIA
-----------------	------------------	----------------	-------------------------------	-----------	--

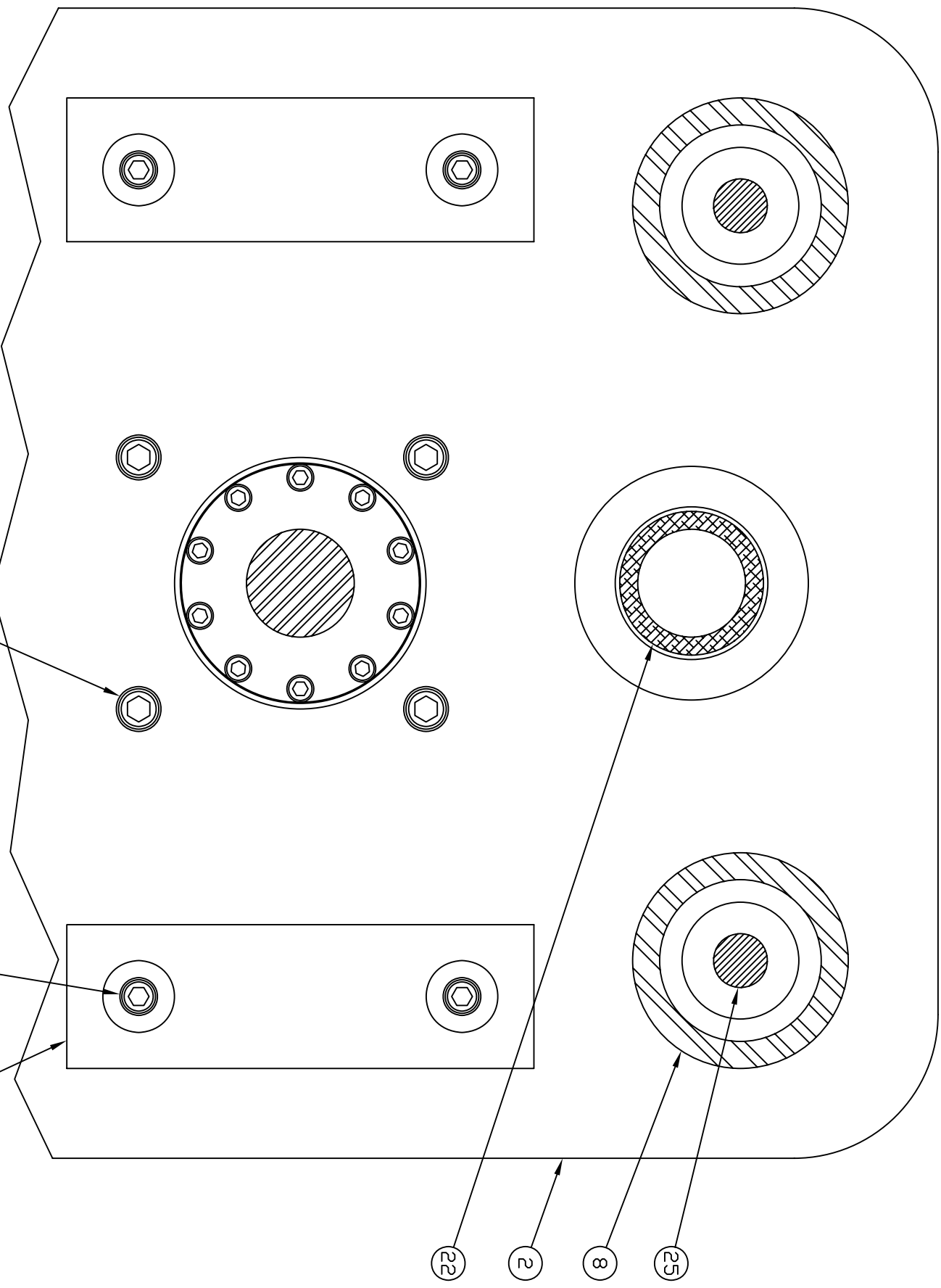

MATERIAL:

SCALE: 1:4

DWN. BY: SEG	DATE: 6-17-99	MODEL: 220 HIH	DESCRIPTION FINAL ASSEMBLY	VIEW F	FOUNDATION EQUIPMENT LLC PITTSBURGH, PENNSYLVANIA
-----------------	------------------	----------------	-------------------------------	-----------	--

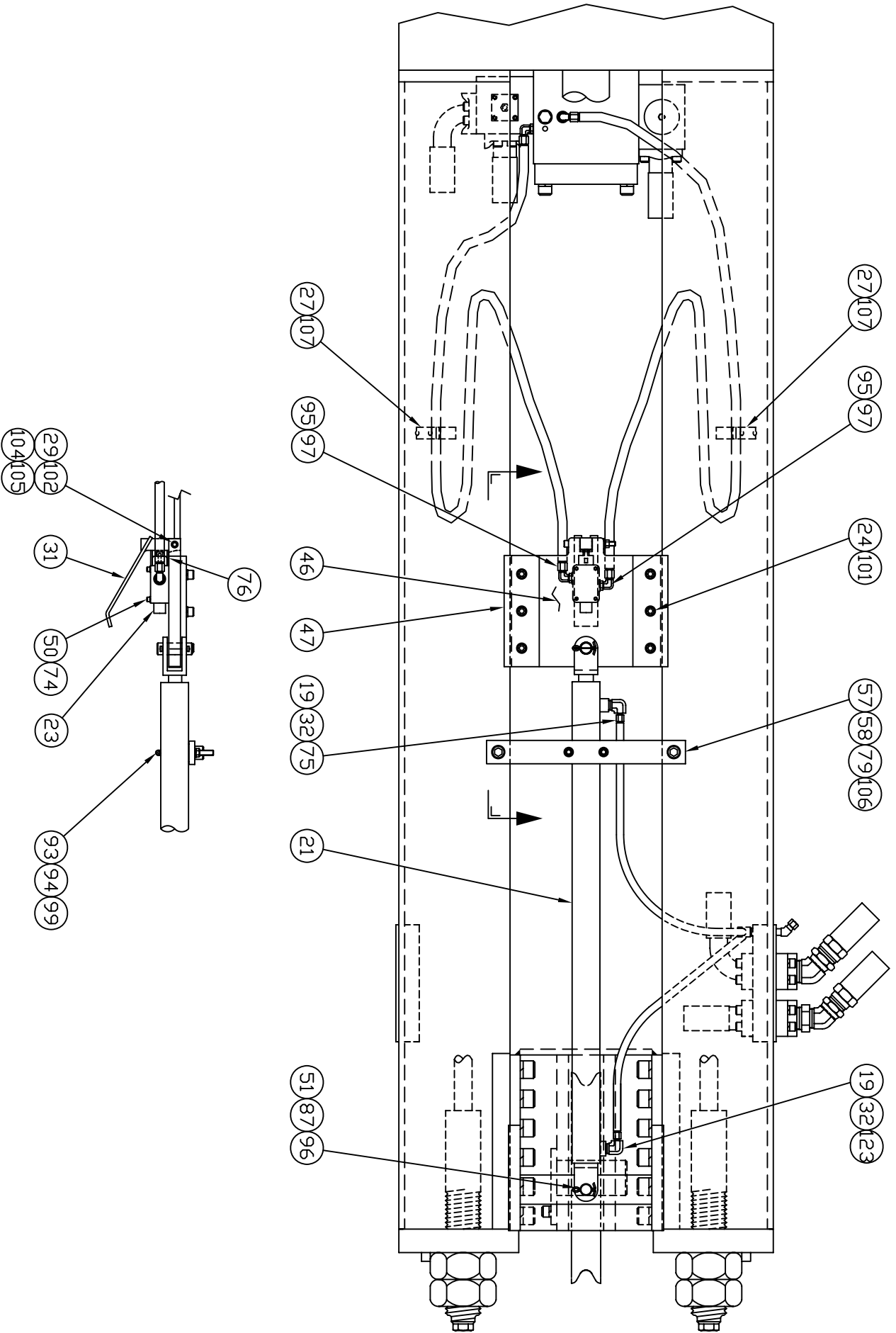

MATERIAL:

SCALE: 1:12

DWN. BY: DATE: 6-17-99

MODEL: 220 HIH

DESCRIPTION: FINAL ASSEMBLY

VIEW: G



FOUNDATION EQUIPMENT LLC
PITTSBURGH, PENNSYLVANIA

Bill of Materials for: 810797**08/06/2007****Drawing # 810797****220 ACTUATOR ASSEMBLY**

Item No	Component ID	Component Description	Quantity	Drawing #	Info Only
1	160883	160 ACTUATOR BASE	1	160883	
2	810621	CONTROL VALVE ASM.	1	810621	
3	160337	.5-13UNC X 5.50 LG SHCS	4		
4	100121	.50 LOCK WASHER MEDIUM	10		
5	100596	#24 SPLIT FLANGE HALF	2		
6	160951	GLAND 220	1	160951	
7	100079	.5-13 X 4.0 LG SHCS	10		
8	160507	-349 O-RING 90 DURO	1		
9	160982	WEAR RING	2		
10	160980	ROD SEAL	1		
11	110119	2-225 O-RING	1		
12	160733	ROD 220	1	160733	
13	160717	CYLINDER	1	160717	
14	400045	.75-10 x 3.5 LG SHCS	8		
15	100069	.75 LOCK WASHER MEDIUM	8		
16	160519	-356 O-RING 90 DURO	4		
17	100646	FITT2P-02P000000-000S007	1		
18	160719	PISTON 220	1	160719	
19	160978	PISTON SEAL	2		
20	160924	2.75-12 ESNA NUT	1		
21	160417	TUBE	1	160417	
22	130057	FITT2L-06M06R000-000H001	2		
23	160349	.75-10UNC X 7.50 LG SHCS	8		
24	160281	.75 BELLEVILLE WASHER	8		
25	160323	CARTRIDGE	2		
26	160315	.75-10UNC ESNA NUT	8		
27	160523	TRANSFER HOUSING	1	160523	
28	160815	FITT2L-24F24M000-0000008	1		
29	160813	2.50PA - 1.50PA ADAPTER	1	160813	
30	100513	.5-13 X 1.5 LG SHCS	4		
31	400379	2-232 O-RING 90 DURO	2		
32	160525	CARTRIDGE COVER	1	160525	
33	810701	DIN CARTIDGE SIZE 80	1	810701	
34	100212	1.0-8 X 4.00 LG SHCS LOC WEL	4		
35	100845	FITT2P-04P000000-000S007	2		
36	810683	HIH CHECK VALVE ASM	1	810683	
37	160343	.5-13UNC X 4.25 LG SHCS	6		
38	100119	.5-13 X 1.25 LG SHCS LOC WEL	8		
39	160533	2.50 BLANK FLANGE CODE 61	1		
40	400787	1.00 H. C. LOCK WASHER	4		
41	110929	2-226 O-RING 90 DURO	2		

Bill of Materials for: 810797

08/06/2007

Drawing # 810797

220 ACTUATOR ASSEMBLY

Item No	Component ID	Component Description	Quantity	Drawing #	Info Only
43	400213	FITT2P-06P000000-000S007	1		
44	160509	-349 BACK-UP WASHER	1		
45	160976	ROD WIPER	1		
46	160974	MODULAR BACK-UP	1		
47	810777	ORIFICE PLUG	1	810777	
48	160972	WEAR BAND	1		
49	110602	111 O-RING	1		
50	LABOR	HALF HOURS	40		

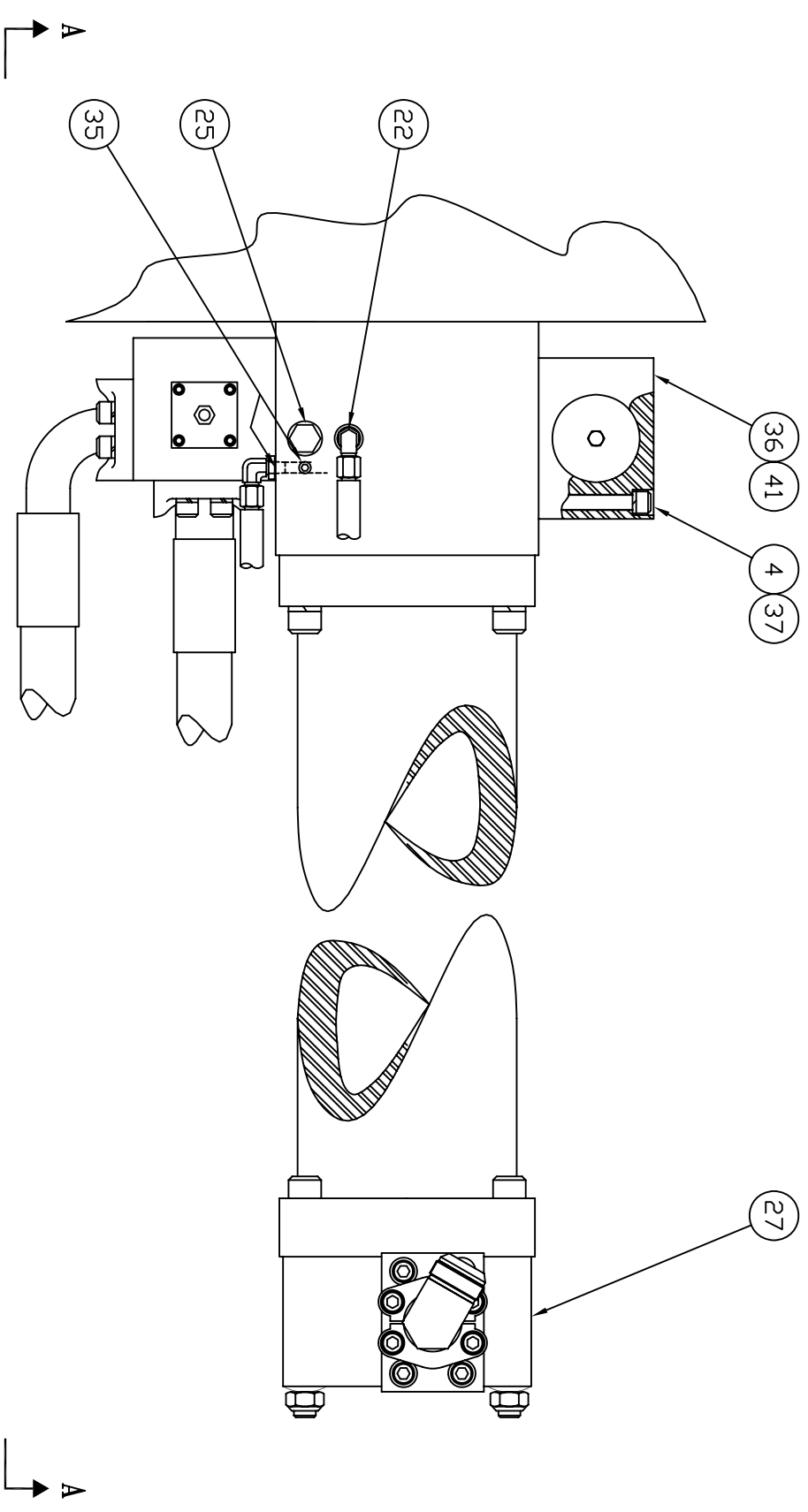

MATERIAL:

SCALE: 1:6

DWN. BY: SEG	DATE: 6-16-99	MODEL: 220 HIH	DESCRIPTION ACTUATOR ASSEMBLY	VIEW M		FOUNDATION EQUIPMENT LLC PITTSBURGH, PENNSYLVANIA
-----------------	------------------	----------------	----------------------------------	-----------	---	--

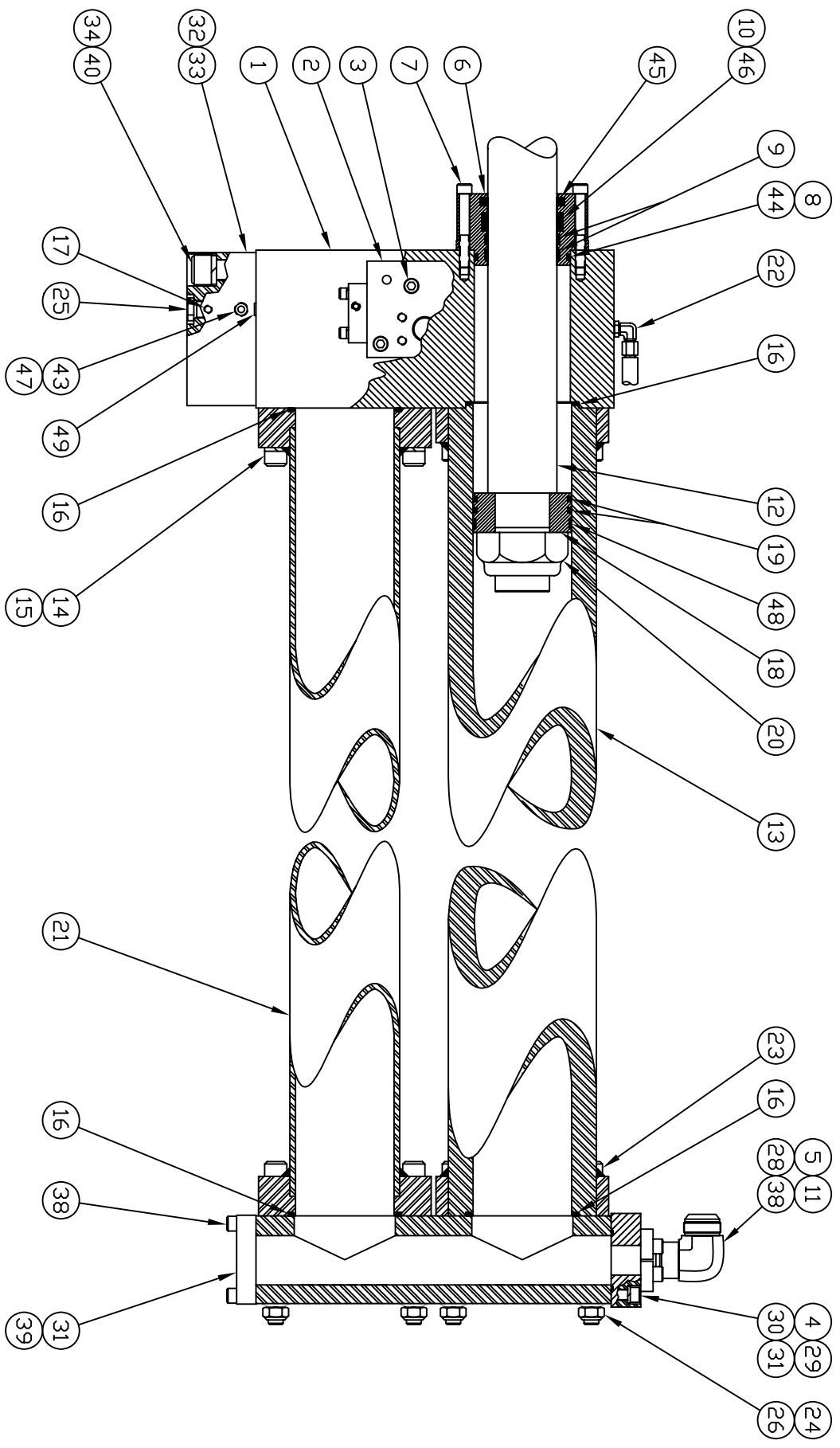

MATERIAL:

SCALE: 1:8

DWN. BY: SEG	DATE: 6-16-99	MODEL: 220 HIH	DESCRIPTION ACTUATOR ASSEMBLY	VIEW A	FOUNDATION EQUIPMENT LLC PITTSBURGH, PENNSYLVANIA
-----------------	------------------	----------------	----------------------------------	-----------	--

Bill of Materials for: 810621

09/14/2006

Drawing # 810621

CONTROL VALVE ASM.

Item No	Component ID	Component Description	Quantity	Drawing #	Info Only
1	160157	VALVE BODY	1	160157	
2	160159	SPOOL	1	160159	
3	160147	SPRING CAP	1	160147	
4	160153	SPOOL STOP	1	160153	
5	160275	SPOOL SPRING	1		
6	100105	.312-18 X 1.0 LG SHCS LOC WEL	1		
7	100037	2-222 O-RING 90 DURO	2		
8	160856	.25-20UNC x 5.00 LG SHCS	4	160856	
9	160161	COVER	1	160161	
10	160333	.375-16UNC X 1.75 LG SHCS	4		
11	160329	109-O-RING 90 DURO	1		
12	100646	FITT2P-02P000000-000S007	4		
13	810777	ORIFICE PLUG	1	810777	
14	160323	CARTRIDGE	1		
15	140255	2-113 O-RING 90 DURO	4		
16	400149	.375 LOCK WASHER	4		
17	100559	.25 LOCK WASHER	4		
18	100293	.312 FLAT WASHER	1		
19	100845	FITT2P-04P000000-000S007	1		
20	160991	SPOOL FITTING	1		
21	110119	2-225 O-RING	1		
22	LABOR	HALF HOURS	10		

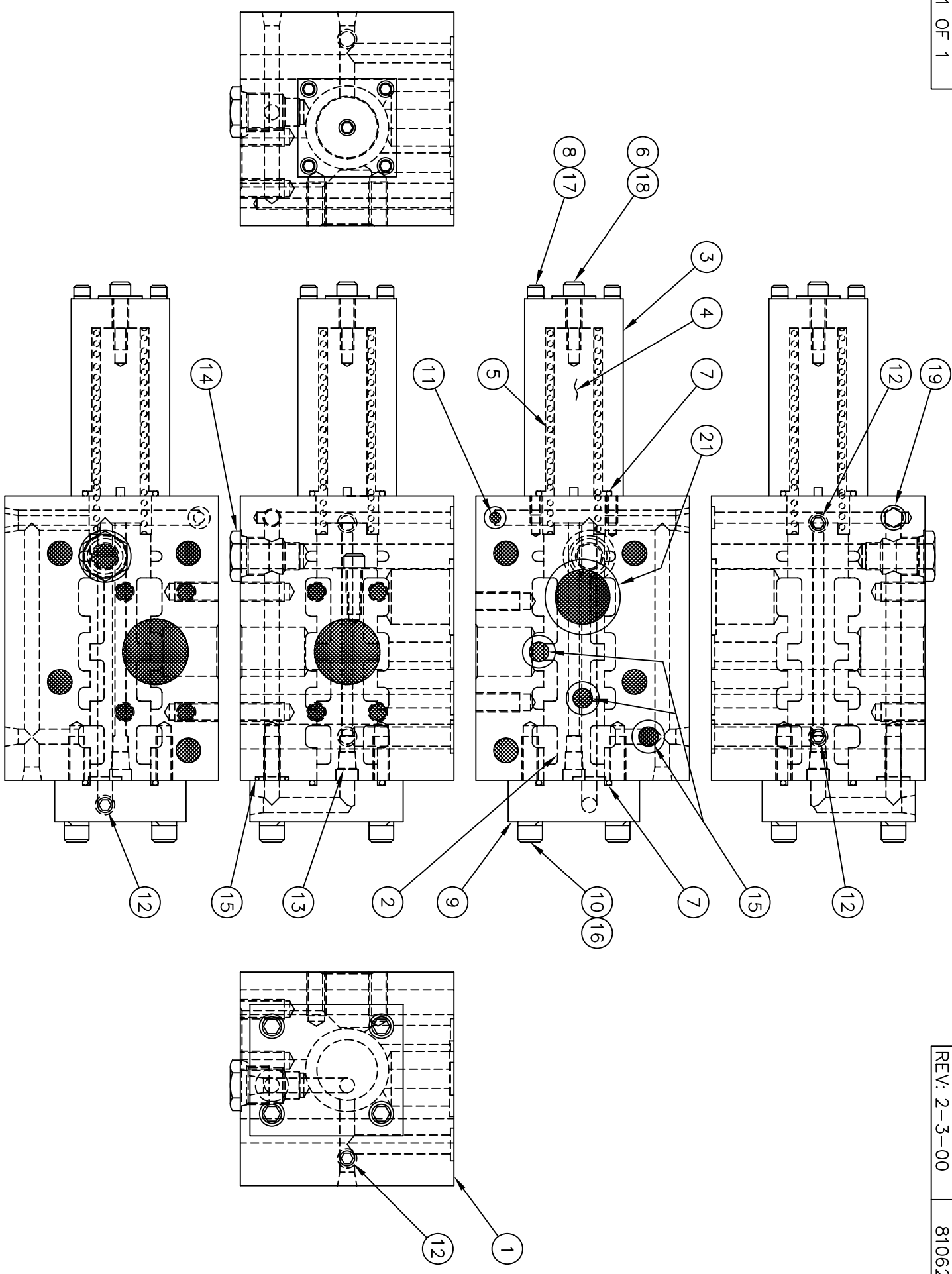

MATERIAL: STL.

SCALE: 1:3

DWN. BY: SJO
DATE: 5-18-93

MODEL: 115 HIH

DESCRIPTION
VALVE ASSEMBLY

VIEW



HYDRAULIC SYSTEMS, INC.
4063 LIBERTY AVENUE
PITTSBURGH, PA 15224

Bill of Materials for: 810683**08/06/2007****Drawing # 810683****HIH CHECK VALVE ASM**

Item No	Component ID	Component Description	Quantity	Drawing #	Info Only
1	160411	CHECK BODY	1	160411	
2	160441	CHECK POPPET	1	160441	
3	160443	CHECK COVER	1	160443	
4	400379	2-232 O-RING 90 DURO	1		
5	110735	.5-13 X 2.5 LG SHCS	4		
6	100121	.50 LOCK WASHER MEDIUM	4		
7	160765	SPRING	1		
8	110929	2-226 O-RING 90 DURO	2		
9	LABOR	HALF HOURS	1		

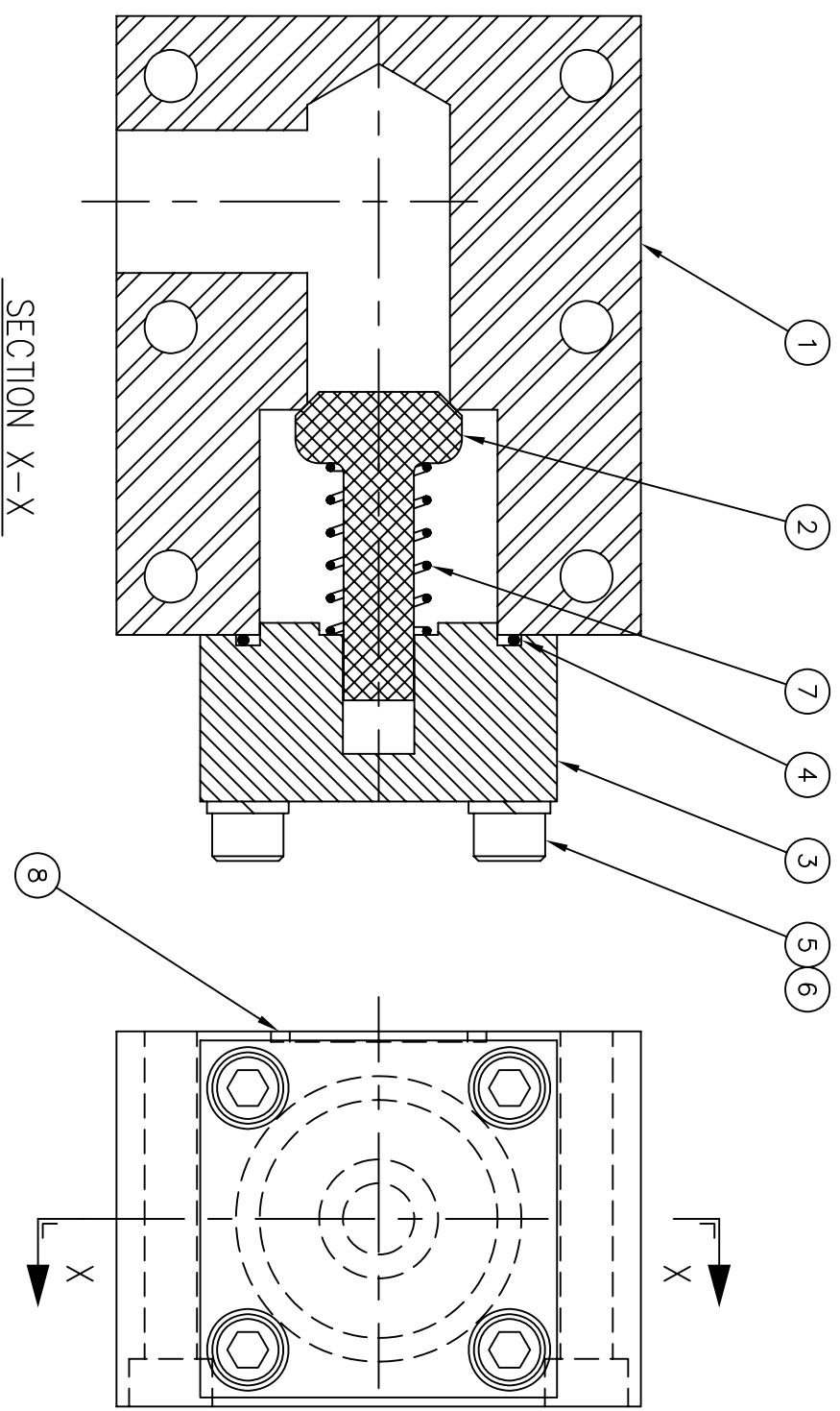

MATERIAL: ~

SCALE: 1:2

DWN. BY: SEG	DATE: 2-20-96	MODEL: 115 HIH	DESCRIPTION CHECK VALVE	VIEW	 FOUNDATION EQUIPMENT LLC PITTSBURGH, PENNSYLVANIA
-----------------	------------------	----------------	----------------------------	------	--