

APE/JUNTAN DAILY CHECKLIST

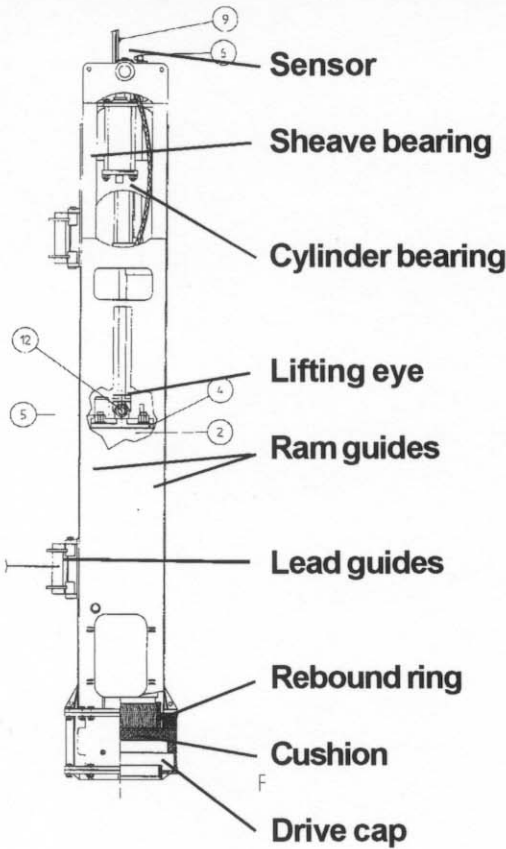

JUNTAN HAMMER



- Grease ram guides twice daily
- Drive cap 4 shots of grease every 2 hours
- Cylinder lifting eye 4 shots daily
- Cylinder bearing 4 shots daily
- Lead guides daily
- Lifting sheave pin and bushing 4 shots daily
- Check condition of Cushion daily
- Check condition of rebound ring bi-weekly
- Check and tighten proximity switch daily
- Check wear pads on corners of ram daily
- Tighten bolts on lifting eye daily

Check accumulators and seals by APE/Junttan test method. If you do not know the method then call APE for details.

Note: Always read the manual for complete details on how to maintain this equipment.

APE POWER UNIT

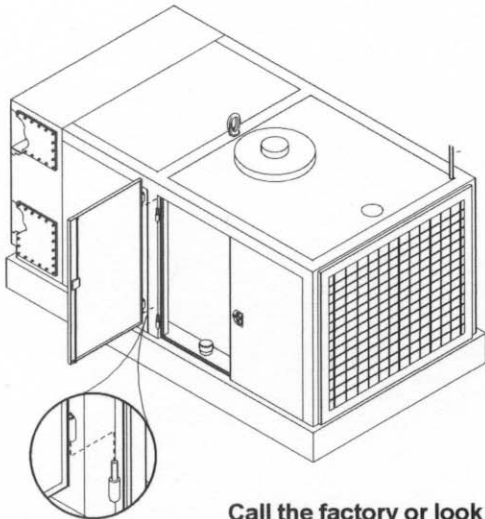

Call the factory or look on our website for the proper filters for your power unit.

- Check water level
- Check battery level
- Check engine oil level
- Check hydraulic oil level
- Check oil in gearbox on back of engine
- Check fuel level
- Check rain cap on exhaust
- Check fan belts
- Check air filter
- Record hour meter
- Check all electric cables
- Inspect hoses
- Make sure power unit sits level



American Piledriving Equipment, Inc.
 Seattle, Washington
 800 248-8498, Fax (253) 872-8710

Aug 2001